

SERVICE MANUAL

MPS-803



CONTENTS

CHAPTER 1	SPECIFICATIONS	1-1
	I. Application	1-2
	II. General feature	1-2
	III. Structure	1-2
	IV. Basic specifications	1-3
	V. General specifications	1-4
	VI. Functional specifications	1-5
	VII. Interface specifications	1-11
CHAPTER 2	OPERATION	2-1
	I. Precautions	2-2
	II. Parts identification	2-3
	III. Operating functions	2-4
	IV. Setting up	2-6
CHAPTER 3	OPERATING PRINCIPLE	3-1
	I. Operating principle	3-2
	II. Operating of the electronic parts	3-6
CHAPTER 4	MAINTENANCE	4-1
	I. Notes for the maintenance	4-2
	II. Disassembly, replacement and adjustment of parts	4-3
	III. Lubrication	4-17
CHAPTER 5	CIRCUIT DIAGRAMS	5-1
CHAPTER 6	PACKAGE DRAWINGS	6-1
CHAPTER 7	TROUBLESHOOTING	7-1

CHAPTER 1
SPECIFICATIONS

I. Application

This Service Manual contains the service information of Commodore personal computer printer model MPS-803.

II. General feature

This is a bi-directional printer of dot impact system using 8 vertical dots, capable of printing 60 cps.

III. Structure

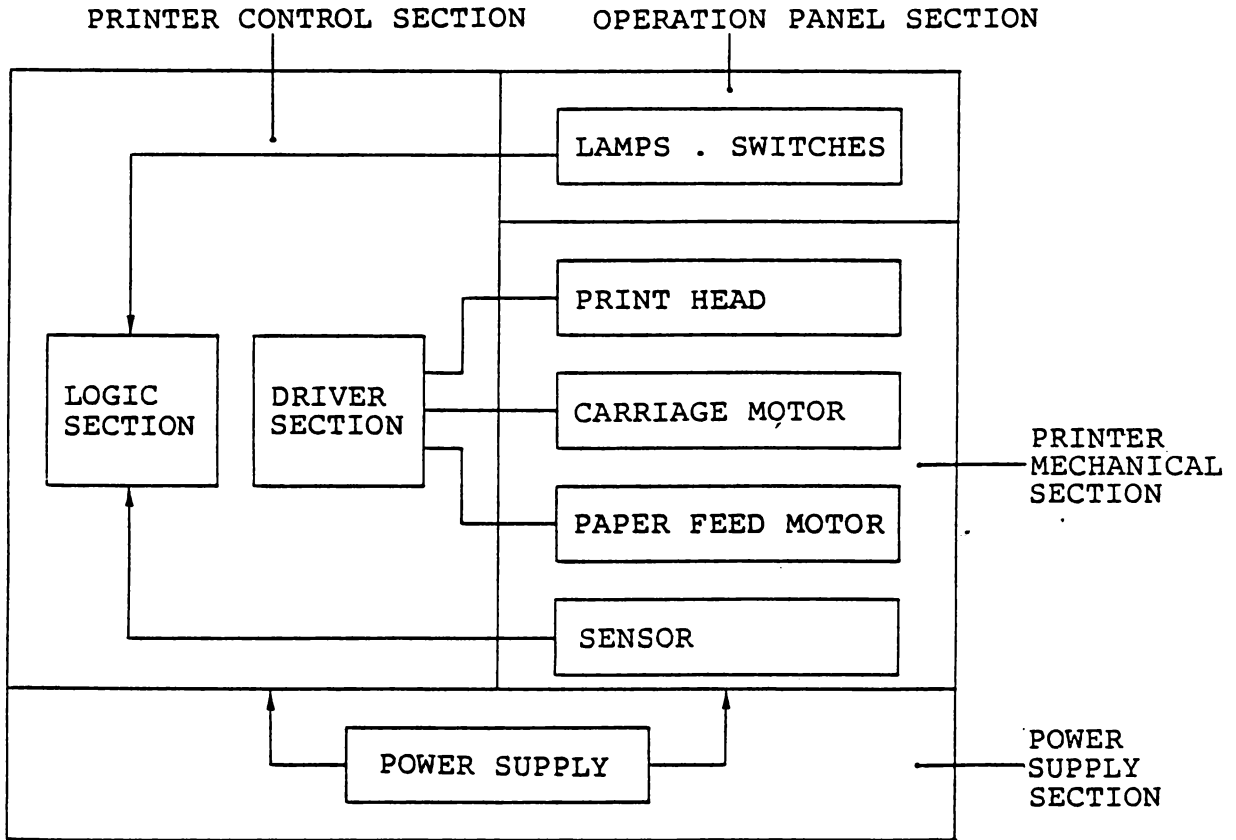

This printer is comprised of the printer control, printer mechanical, operation panel and power supply sections.

IV. Basic specifications

1. Printing method.....Dot matrix impact system
2. Head.....8-pin type
3. Print characters.....Alphabets in capital and small letters, Arabic numerals, symbols and graphic elements
4. Kinds of marks.....Random combination in vertical and horizontal directions of vertical 7-dot units.
5. Character code.....COMMODORE 8-bit code
6. Standard character size.....Vertical 7 dots (2.4mm)
Horizontal 5 dots (2.0mm)
7. Dot size.....0.3mm (wire diameter)
Horizontal pitch...1/60 inch
Vertical pitch.....1/72 inch
8. Print speed.....60 cps
9. Printing directions.....Bi-directional shortest distance printing
Mark printing.....Uni-directional shortest distance printing (rightwards)
10. Max number of columns.....80 columns
11. Character pitch.....10 cpi
12. Line pitches.....6 or 8 lpi (switch selectable)
72/7 lpi...mark printing
13. Line feed speed.....4 lps....character printing (6 lpi)
5.6 lps...mark printing
14. Paper feed method.....Friction feed or Pin feed (optional)
15. Ink ribbon.....Cassette type fabric ribbon
width: 8mm
length: 10m
color: black
life: approx. 500,000 characters (ANK)
16. Print paper.....Cut paper
A4 210.8mm (8.3 inches)
letter 216.0mm (8.5 inches)
Paper quality: fine
Regular paper: 45-60 kg/ream
Transfer paper...
34kg/ream x 3
(chemical carbon paper)
.....Continuous paper (option)
101.6mm (4.0 inches)
254mm (10.0 inches)
Paper quality: fine
Regular paper...45-60kg/ream
Transfer paper..
34kg/ream x 3
(point- or line-pasted paper only)
(chemical carbon paper)

17. Copying capability.....original copy + 2 pieces
18. Detection functions
 - a. Home Position and Paper Empty switches
 - HOME POSITION SW: .Left end detection
 - .Printing starts of 24th pulse(dot) after this SW is turned OFF.
 - .Detecting this SW during printing puts the printer in ERROR mode, and printing stops.
 - (LINE RELEASE)
 - b. PAPER EMPTY SW: .Paper empty detection
 - Turns ON after 3 lines from mechanical detection.
19. Operational switching
 - Paper feed: Except mark print mode, either of 1/6 or 1/8 inch feed shall be selected.
 - Listener address: Shall be switched to 4 or 5.
20. Operation section
 - (1) SWITCH PANEL
 - (1).1 POWER LAMP (red)
 - a. POWER indication and PE indication.
 - b. Flickers for PE detection. (at data input)
 - c. Flickers when MOTOR ERROR.
 - (1).2 LF SW
 - a. Has the MANUAL LF function when data is not input.
 - b. Has the PE CANCEL function.
 - c. Has the TEST PRINT START function.

V. General specifications

1. Power.....
 - 1.1 Input
 - AC 100V/117V $\pm 10\%$ 50Hz.60Hz ($\pm 2\%$)
 - AC 220V/240V $\pm 10\%$ 50Hz.60Hz ($\pm 2\%$)
 - 1.2 Output
 - +5V $\pm 5\%$ (AC input $\pm 10\%$)
 - +24V $\pm 4V$ (AC input $\pm 10\%$ test print)
2. Temperature and humidity requirements in operation
 -temperature 5°C - 40°C
 - humidity 10% - 80%
 - Wet-bulb:MAX 27°C No dew allowed.
3. Rush-in current.....20A or less at rated voltage and frequency.
4. Leak current.....1mA or less.
5. Power consumption.....25W or less at test printing at rated voltage and frequency.
6. Insulation resistance....across AC - FG 500V
50M Ω and over
7. Insulating strength.....across AC - FG
No abnormality shall occur after applying 1000V AC for one minute.
8. External dimensions.....334 (W) x 206 (D) x 94 (H) mm
Refer to the Exterior Drawing
9. Weight.....3 kg (approx.)
10. Noise.....63dB or lower
(in rolling ASCII printing)
(when measured by A-SLOW at 1m away horizontally from the front face.)

11. Head service life.....20,000,000 characters and over
(ANK printing)
12. Durability.....MTBF 4,000 hours....excluding
head life
- Conditions:
Duty for POWER ON time: 20%
Duty for characters: 25%
13. Print quality.....Line feed accuracy 4.23 ± 1.0
(1/6 inch feed)
Accumulative line feed accuracy
 42.33 ± 1.5
(10 lines, 1/6 inch feed)
Column alignment accuracy 0.4 or
less
Accumulative column alignment
accuracy (10 lines) 1.0 or less
Line inclination 1.5 or less
letter paper
(when measured across the first
and last characters) 0.7 or less
fanfold paper
(inclination to the sprocket
holes)

VI. Functional specifications (ROM REVISION U32053A)

1. Principal functions
 - (a) Double-width character output possible by command designation.
 - (b) Mark printing possible. (BIT IMAGE output)
 - (c) In mark printing, repetition possible by instruction.
 - (d) Print start position can be designated by character or dot. (POSITIONING)
 - (e) Standard characters, double-width characters and marks can be mix-printed in one line.
 - (f) Automatic printing when BUFFER FULL or OVER PRINT possible.
 - (g) Print function self-checking program equipped.
 - (h) Reversal printing possible by command designation.
 - (i) From (") X' 22' to (") or CR code,
X' 00' - X' 1F' and X' 80' - '9F' output
the reversal characters of X' 40' - X' 5F' and X' C0' - X'
DF' respectively.
Note that CR code always executes carriage return.
2. Print modes
 - (a) STANDARD CHR PRINT mode: bi-directional
 - (b) DOUBLE-WIDTH CHR PRINT mode: bi-directional
 - (c) MARK PRINT mode: uni-directional
Reversal print is uni-directional to avoid damaging the
print head.
For the character font, either of GRAPHIC (SA=0) or
BUSINESS (SA=7) mode can be designated by the secondary
address.

3. Interface specifications
 COMMODORE serial interface
 CON LINE range: from LISTENER ADDRESS reception to UNL reception)
 Refer to the INTERFACE SPECIFICATIONS.
4. Function codes
 - (a) NL (X' OA')
 Print command. Executes line feed after printing. Same as LF if used singly. Does not cancel PRINT mode. Cancels RVS ON.
 - (b) CR (X' OD')
 Print command. Executes line feed after printing. Same as LF if used singly. Does not cancel PRINT mode. Cancels RVS ON and X' 22' (") function.
 - (c) BS (X' 08')
 Designation command for MARK PRINT mode. Executes MARK PRINT mode after BS to SI or SO. POS and ESC-POS designation right before BS input are invalid. Valid status codes between BS and SI or SO are BS, POS, ESC-POS, SUB, NL and CR. MARK PRINT remains designated for the following line if NL or CR is valid. If 8th bit of the MARK data is "1" or "0", the data works as function code.
 - (d) SO (X' OE')
 Designation command for DOUBLE-WIDTH CHR PRINT mode. This mode is valid after SO to SI or BS. POS and ESC-POS designation right before SO input are invalid. Valid function codes between SO and SI or BS are SO, POS, ESC-POS, GRAPH, BUSINESS, RVS ON, RVS OFF, NL and CR. This mode remains designated for the following line if NL or CR is valid.
 - (e) SI (X' OF')
 Designation command for STANDARD CHR PRINT mode. Use this print mode right after turning on the power. This print mode is valid after SI to SO or BS. POS and ESC-POS designation right before SI input are invalid. Valid function codes between SI and SO or BS are SI, POS, ESC-POS, GRAPH, BUSINESS, RVS ON, RVS OFF, NL and CR. This print mode remains designated for the following line if NL or CR is valid.

- (f) POS (X' 10') POS"ab" ab is a 2-digit numeric code. Designation of print start position. Absolute position designation by standard character size.

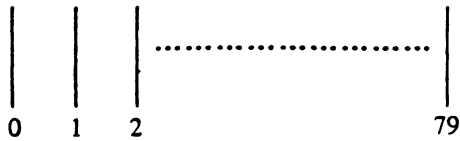

ab≥80 is invalid.
If numeric code is not used, position designation is not guaranteed.

Example

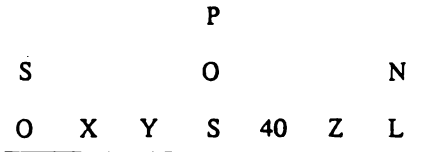

Print executed at 40th and 41st columns counted from 0 with standard character size.

2 columns of double-width character

In the example above, if 79 replaces 40, this designation results in overprint. Automatic line feed is done and printing is done at 0 and 1st columns, and line feed is done.

Basically, printing data exceeds the printing range, OVER PRINT occurs due to this designation and automatic line feed is performed. Characters exceed including the END point are printed at the head of the following line. If this designation is continued, only the last value is valid.

- (g) ESC (X' 1B') ESC-POS-HP-LP Designation for print start position. Absolute position designation by dot.

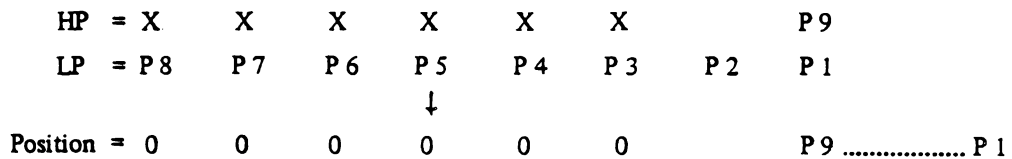
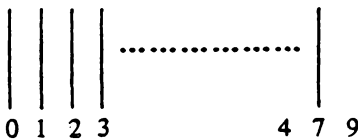

HP.LP≥480 is invalid.

Printing of standard and double-width characters after designating 479≥HP.LP≥475 is automatic and done at the head of the following line including line feed. Double-width characters after designating 479≥HP.LP≥469 are processed in the same way. If this designation is continued, only the last value is valid. Only POS can be combined with ESC, print output except POS is not guaranteed.

- (h) SUB (X' 1A') SUB.n.data(≥ 128)
 Repetitive designation command for MARK data.
 This command is valid in the MARK PRINT mode, and SUB code (1BYTE) is ignored in the STANDARD CHR and DOUBLE-WIDTH CHR PRINT mode.
 $255 \geq n \geq 0$ If 0 is set, it is considered as 256.

exp.

			S			D			
	S			B	U		A		N
						T			
	I	ABC	S	B	n	A	I	A
	.			.				.	
	.	┌		└				.	
	.			.				.	
	.	40		CHRS				.	
	0			239				.	

As described in the position designation, standard and double-width characters after designating (479-239) $\geq n \geq$ (475-239) are printed at the head of the following line including automatic printing and line feed. Double-width characters after designating (479-239) $\geq n \geq$ (469-239) are processed in the same way. If data value of this command is smaller than 128, the whole designation is ignored.

When data of this command exceeds the printing range, printing proceeds and starts from the head of the following line including line feed.

- (i) GRAPH (X' 91')
 GRAPHIC mode designation command
- (j) BUSINESS (X' 11')
 BUSINESS mode designation command
 The above two commands are used to change the character font.
 This command is cancelled by the print command (CR, LF).
- (k) RVS ON (X' 12')
 REVERSE designation command
- (l) RVS OFF (X' 92')
 REVERSE cancel command
 The above two functions are valid in the STANDARD and DOUBLE-WIDTH CHR PRINT modes.
 The designation command is cancelled by the print command (CR, LF).
 The above (i) (j) (k) (l) are not cancelled by automatic line feed.
- ° Undefined codes are ignored.
 Those codes except POS, ESC-POS, SUB, NL and CR in the MARK PRINT mode are ignored.

5. Reversal printing by ASCII (") X' 22'
 X' 22' - X' 22' in STANDARD and DOUBLE0-WIDTH CHR PRINT modes or X' 00' - X' 1F' and X' 80' - X' 9F' between CR codes do not have their function and output the reverse character of X' 40' - X' 5F' and X' C0 - X' DF' respectively.
 CR code always performs carriage return.
 Therefore, reverse of M is not possible by this function.
 Ordinary character codes follow RVS ON/OFF.

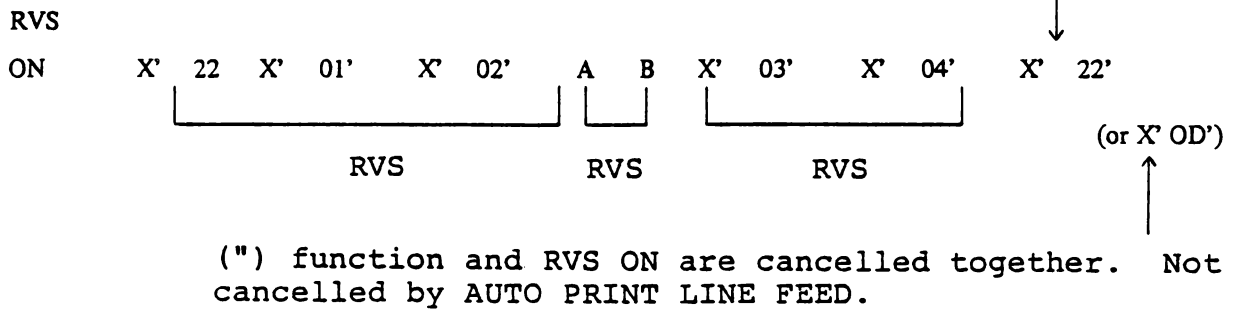
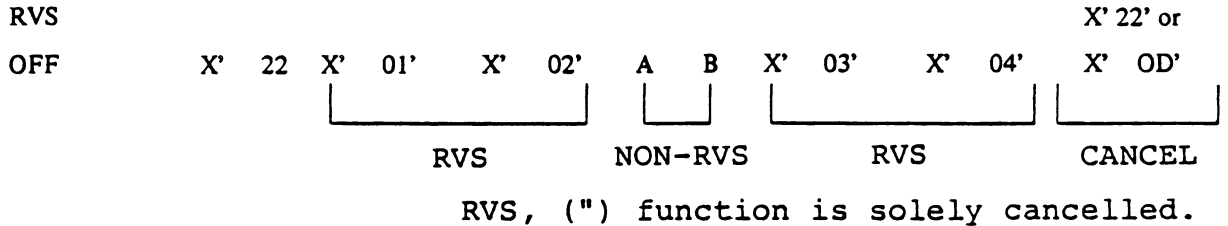

6. Secondary address
 Secondary address is designated by n3 among OPEN, n1, n2 and n3.
 Sent to the printer right after the listener address.
 Secondary address is often omitted.
- (a) Secondary address = 0 GRAPHIC mode
 - (b) " = 7 BUSINESS mode
 - (c) when omitted → GRAPHIC mode
 - (d) when other than 0 or 7 → Invalid
- This function is valid in one ON LINE range, and is switchable by X' 91', X' 11'. If switched by X' 91', X' 11°, it is cancelled by PRINT COMMAND (CR, LF).
 The data sent to the printer is secondary address + X' 60'.
7. Listener address
 Listener address is selected to 4 or 5 by the switch on the logic card.
 The data sent to the printer is listener address + X' 20'.
8. Paper feed function
 Paper feed is executed by LF, CR and line feed after printing.
 Length of feed differs with the mode before.
 STANDARD, DOUBLE-WIDTH CHR PRINT mode → 1/6 inch*
 MARK PRINT mode → 7/72 inch
 * Can select 1/6 or 1/8 by the switch on the logic card.
 Feed by MANUAL switch is valid in OFF LINE mode.
 Feed length follows the print mode right before UNL.

9. Function codes are valid within the ON LINE range and the function setting, set value and data are held even in the OFF LINE mode.

Note that GRAPH/BUSINESS mode follows the secondary address at OPEN. If the same secondary address is received when previously set by X' 91', X' 11' and when a print command (CR, LF) is not received, mode setting by X' 91', X' 11' is held. If different secondary address is received, the mode follows the secondary address.

10. Paper empty detection

⊙ OFF LINE: Data is taken in. BUSY status turns on at the start of mechanical operation. At this time, PE detection works and the POWER LAMP flickers. (at data input)

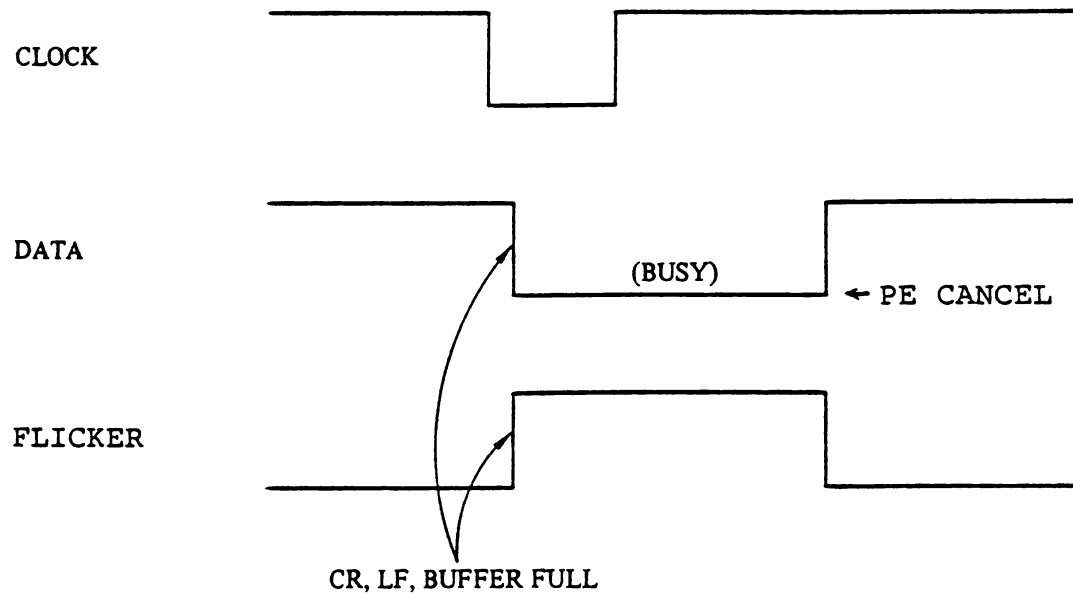

⊙ ON LINE: Detection occurs at data input. POWER LAMP flickers. BUSY at the LAST data is valid.
 * PE detection occurs at 3 lines after mechanical detection.

11. COMMODORE Serial Interface
 . See Timing and Flow charts.
 . See the Specifications for connectors and layout.
12. Automatic printing function
 Two types are available.
- (1) Print by data buffer full
 At the end of printing, the dot position holds the last dot point.
 This is due to the control means, and there is no difference between the input data and print output.
 In this case, printing is uni-directional in any mode.

- (2) When the data exceeds the print range.
When the data exceeds the print range, printing is executed to the last column followed by a line feed. Excess data is printed from the head of the following line.
(Printing not started at the input of 480 columns.)
If data exceeds the margin point, auto line feed is executed and the excess data is printed on the following line.
Reference: buffer size 152 BYTE
Number of bytes contained
POS: 4 SUB: 4
SI . SO . BS . NL . CR . RVS . GRAPH/BUSINESS: 1

13. Switch panel

- (1) LF SW
(a) During OFF LINE, paper feed is executed without regard to the paper.
Continuous LF is executed by pressing it for over 0.5 sec.
(b) If once after the PE detection occurs, load the paper and press this switch to cancel the PE detection.
(Paper feed is not done.)
(c) This switch is invalid during ON LINE.
Still it has the function to cancel PE until the first print command and buffer full. Invalid after this until UNL.
(d) Turn the power on while pressing this switch to start automatic self printing.
- (2) POWER LAMP
(a) Comes on when power is input.
(b) Flickers upon PE detection until it is cancelled.
(2.5 times/sec)
(c) Flickers upon the motor error. (10 times/sec)

14. Self diagnosis

- (a) At POWER ON
If CPU operation is correct, the carriage moves to left (HOME POSITION) and then to the center to stop.
- (b) POWER ON while pressing LF SW
Self printing starts.
Performs function check excluding the interface. During self printing, manual line feed is invalid. Turn power off to cancel the self diagnosis function.

VII. Interface specifications

1. Input connector (TCS4460-01-1011: Hoshi Elec. K. K.)

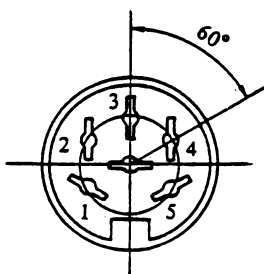

PIN NO.	SIGNAL
1	SERIAL SRQ
2	GND
3	SERIAL ATN
4	SERIAL CLK
5	SERIAL DATA
6	RESET

2. Electrical requirements
 Other requirements: refer to the circuit diagram.

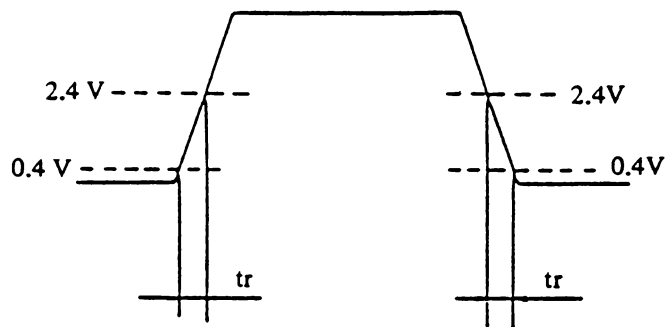

HIGH level 2.4 (V) or over
 LOW level 0.4 (V) or lower

Other requirements: refer to the circuit diagram.

3. INTERFACE CIRCUIT DIAGRAM

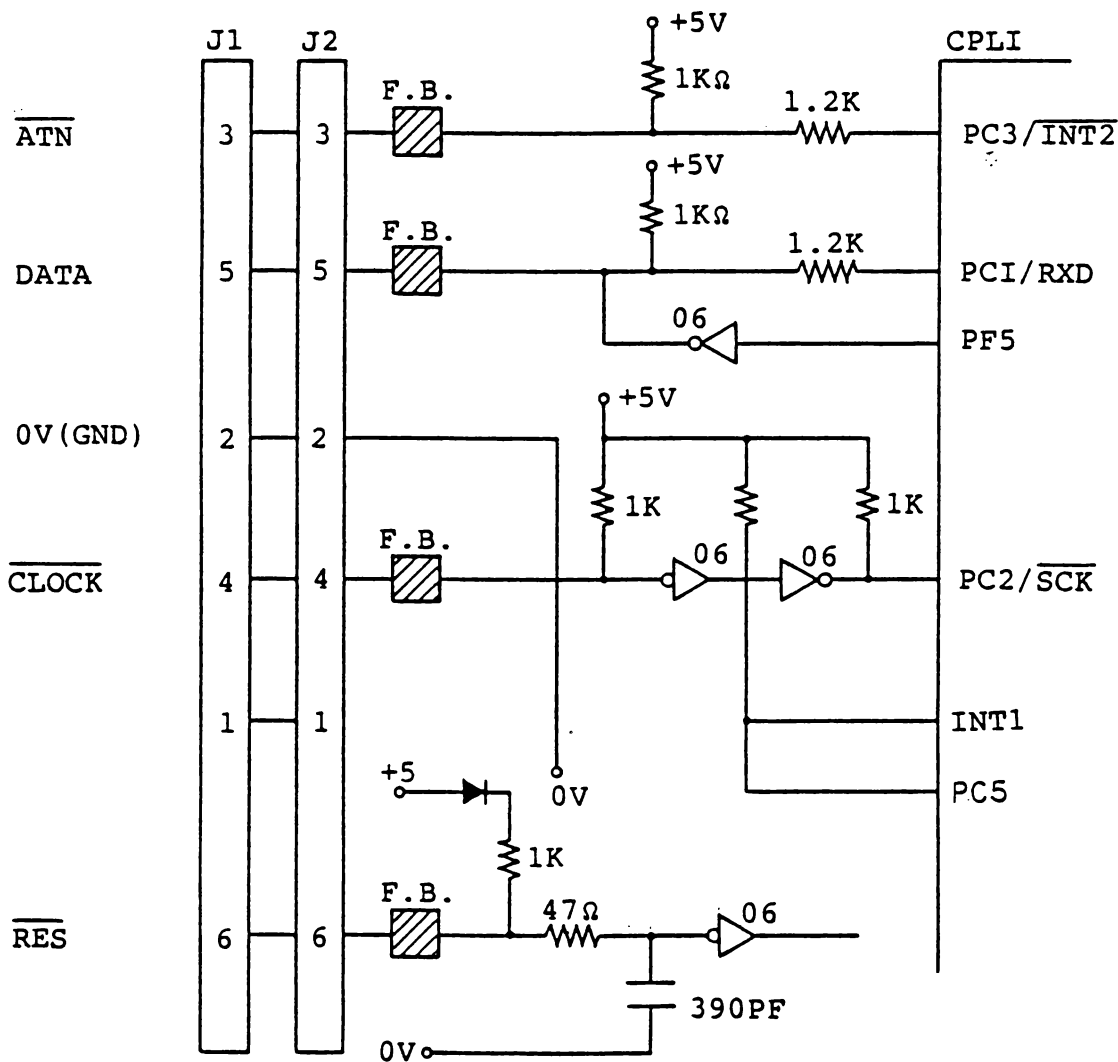

F.B.: FERRITE BEADS
 CPU : μ PD7811 (NEC)

4. Interface functions

- a. Listener function directly connected by cable to CBM serial bus. (SRQ, CLK and ATN signals are not controlled by this device.)
- b. Listener address can be set to 4 or 5 by switch.
Listener address 4: reception data 24 (hexadecimal)
Listener address 5: reception data 25 (hexadecimal)
- c. Secondary address (SA) can be set to 0 or 7.
SA = 0 (reception data 60): GRAPHIC mode
SA = 7 (reception data 67): BUSINESS mode
- d. Data input to this device does not finish until the BUSY status inside this device goes off.
- e. If this device turns into the ERROR status due to a disorder within this device.
Response to the bus is not executed at all.

4.1 CBM serial interface

a. Data structure

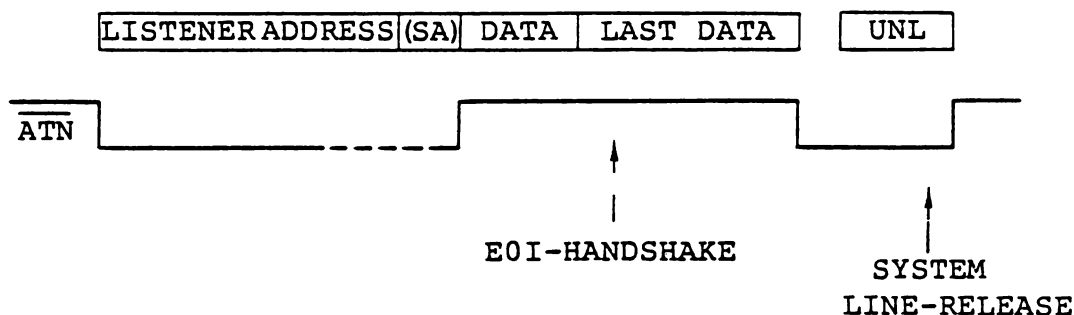

- (1) Data is processed by synchronous transfer with CLOCK.
- (2) The first bit is the LSB. All the bits are of 8-bit construction.
- (3) Listener address data is X' 24 or X' 25. (4 or 5)
- (4) SA is X' 60' or X' 67'. X' 60' is used when SA is omitted. (SA is 0, 7)
- (5) If address is not identified.
SYSTEM LINE-RELEASE is executed.

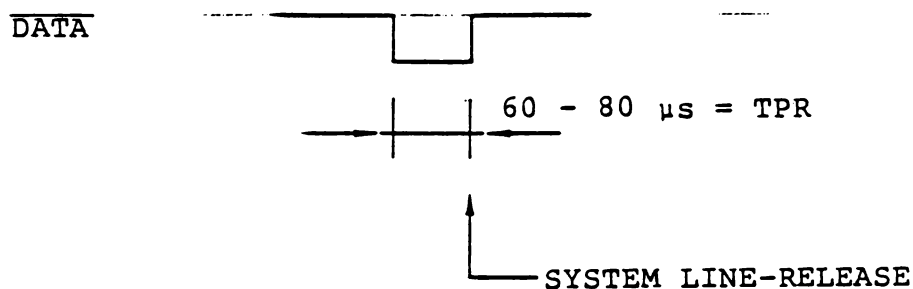

REFERENCE

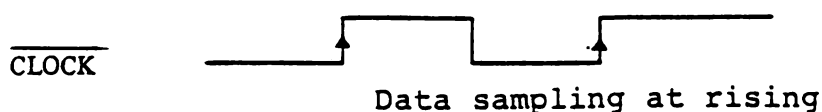

5. Program general flow
 (This flowchart is not precise. Shows the conception of data flow.)

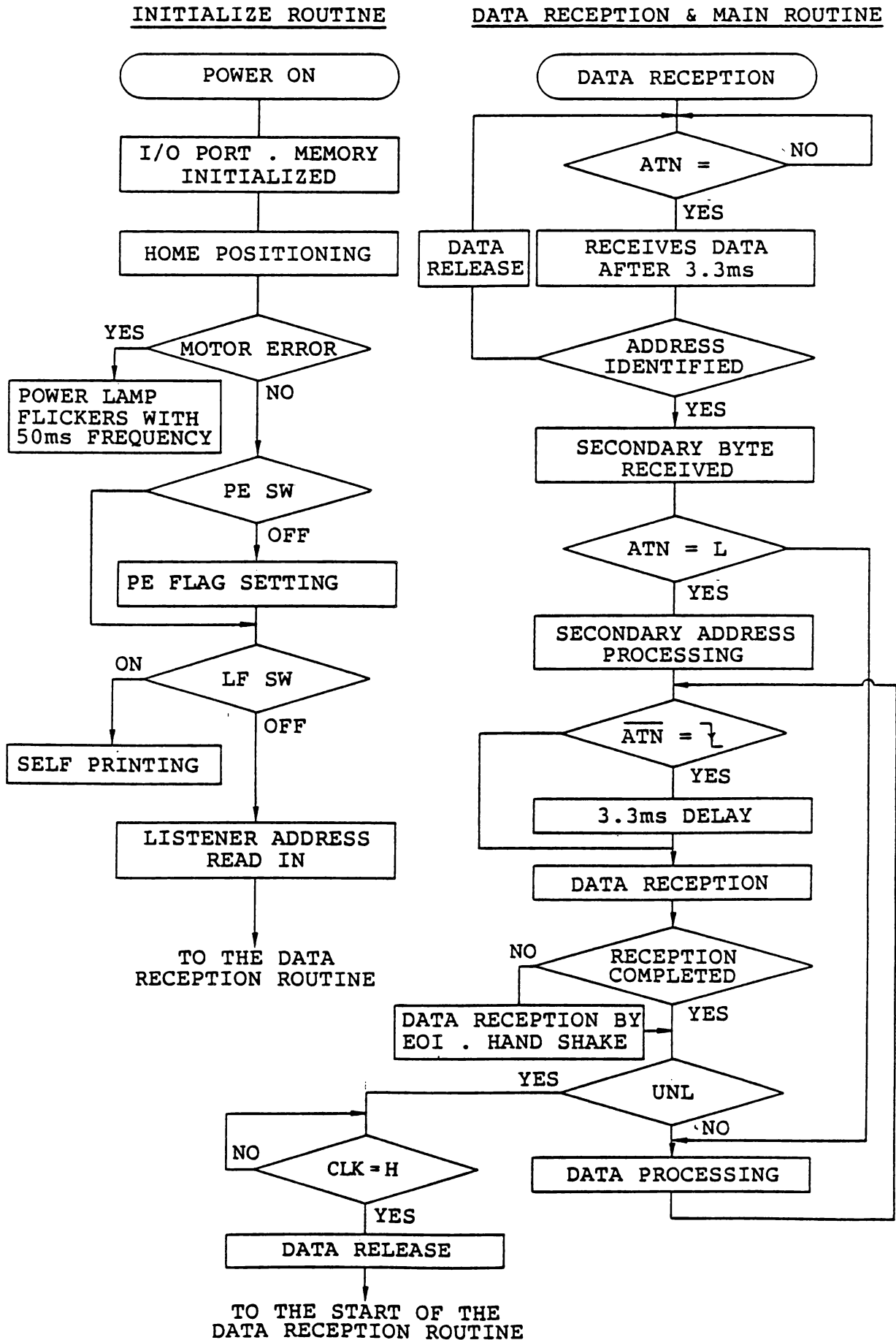

LF SW INTERRUPT

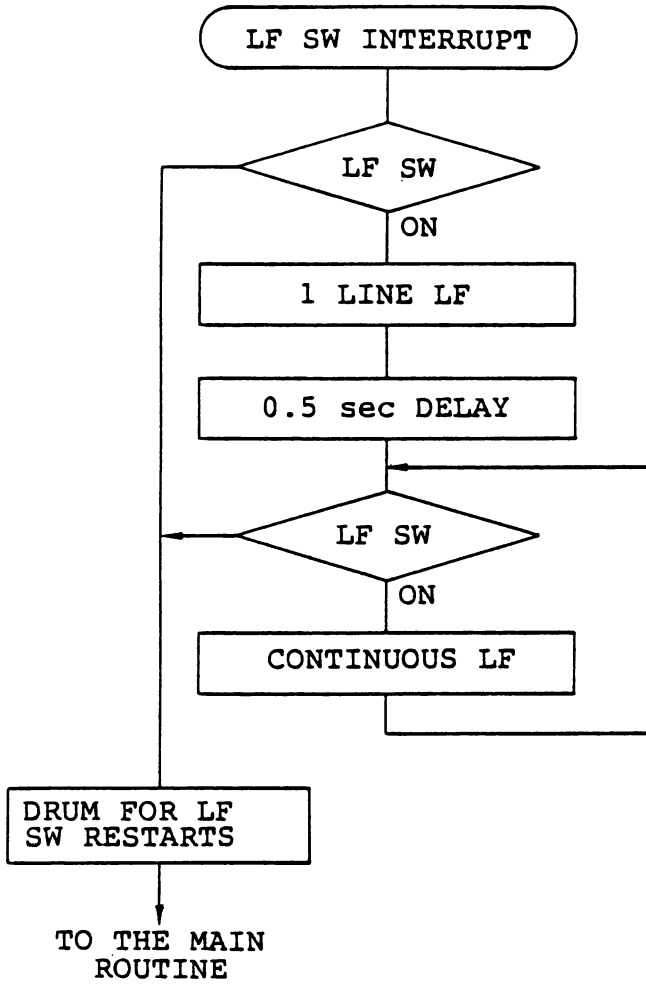

DATA PROCESSING ROUTINE

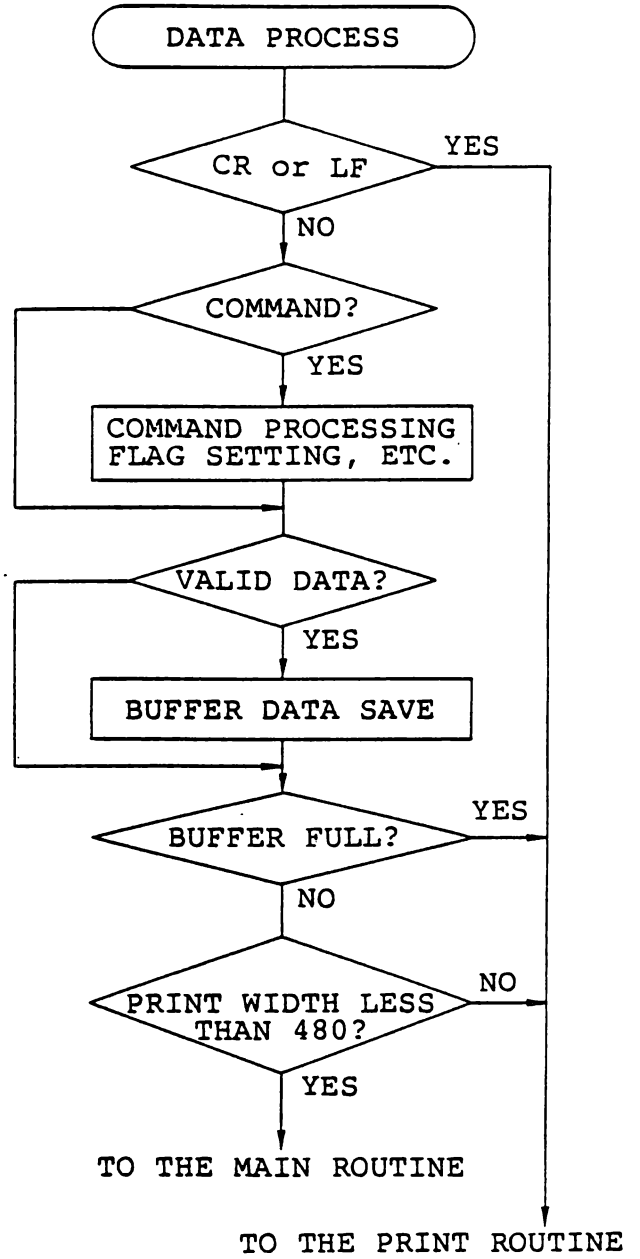

PRINT ROUTINE

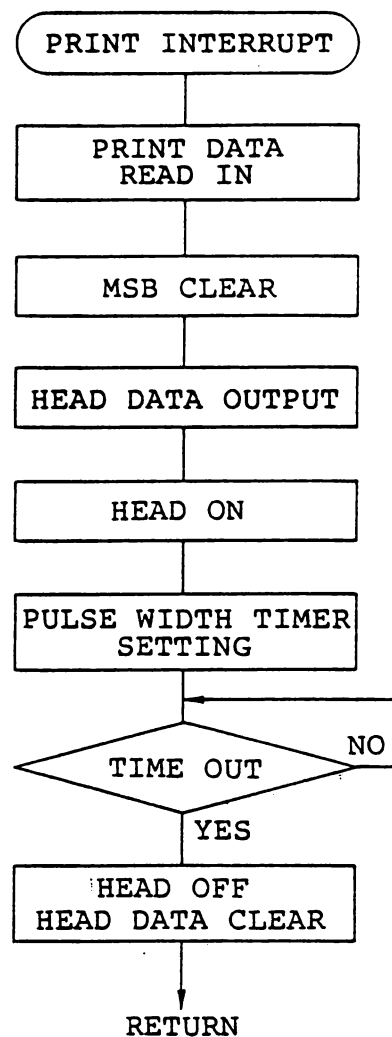
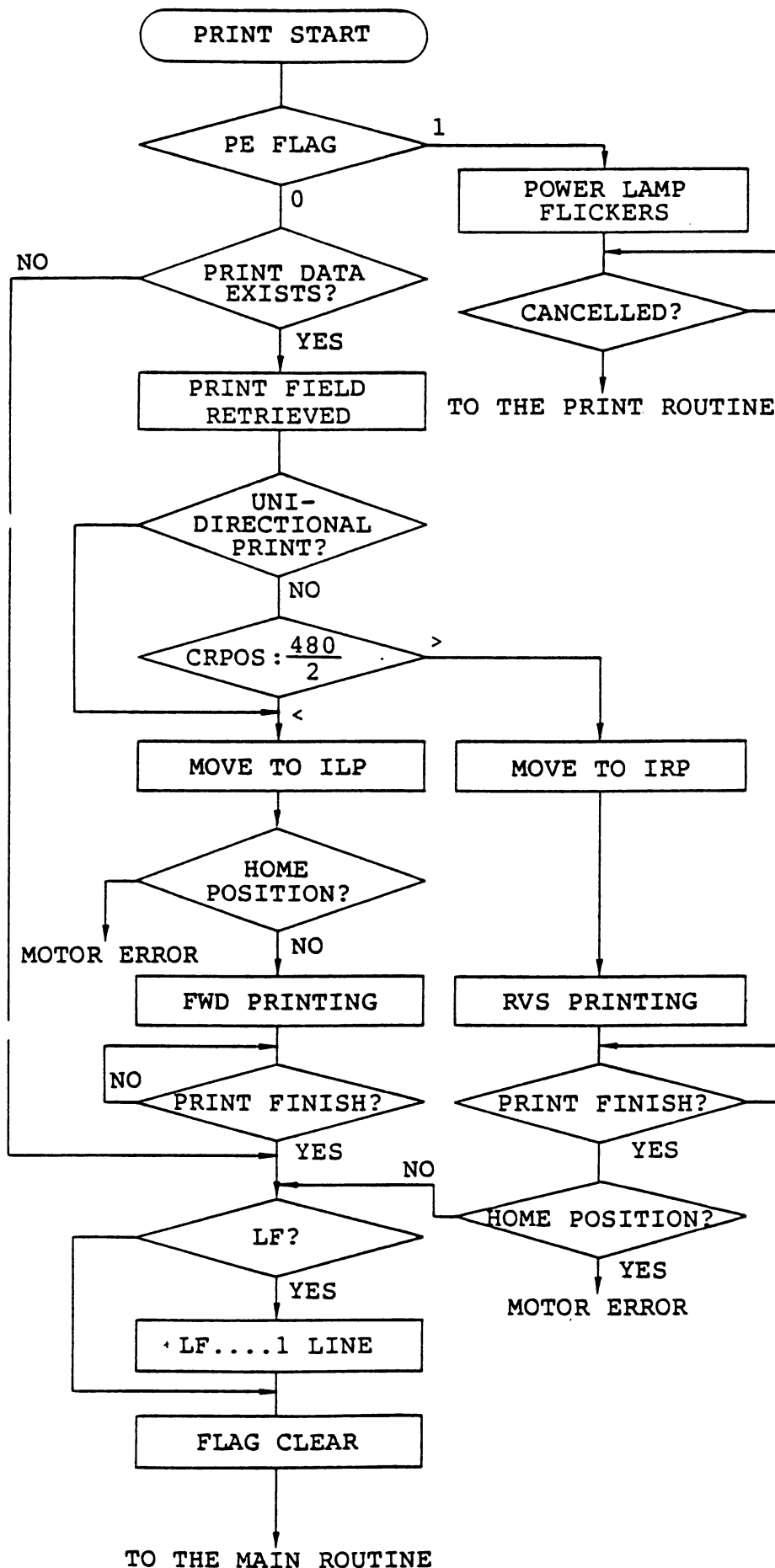

GRAPHIC MODE

	0	1	2	3	4	5	6	7	8	9	A	B	C	D	E	F
0		POS														
1		BUS								GRAPH						
2		RVS ON								RVS OFF						
3																
4																
5																
6																
7																
8	BS															
9																
A	LF	SUB														
B		ESC														
C																
D	CR															
E	SO															
F	SI															

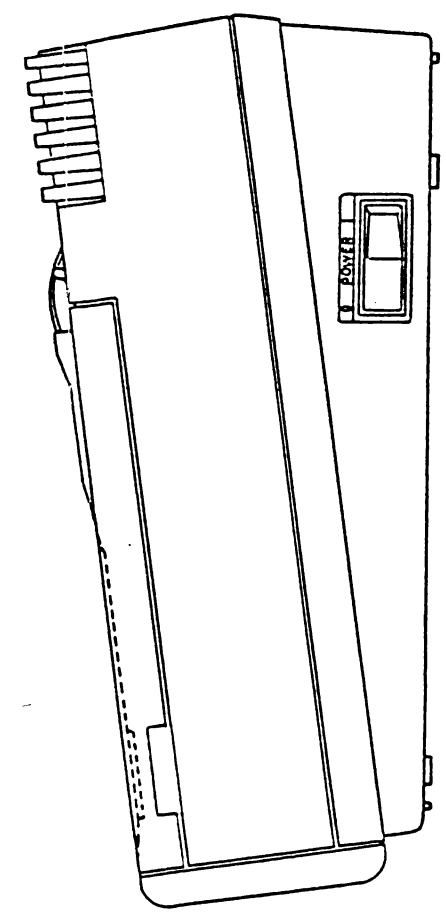
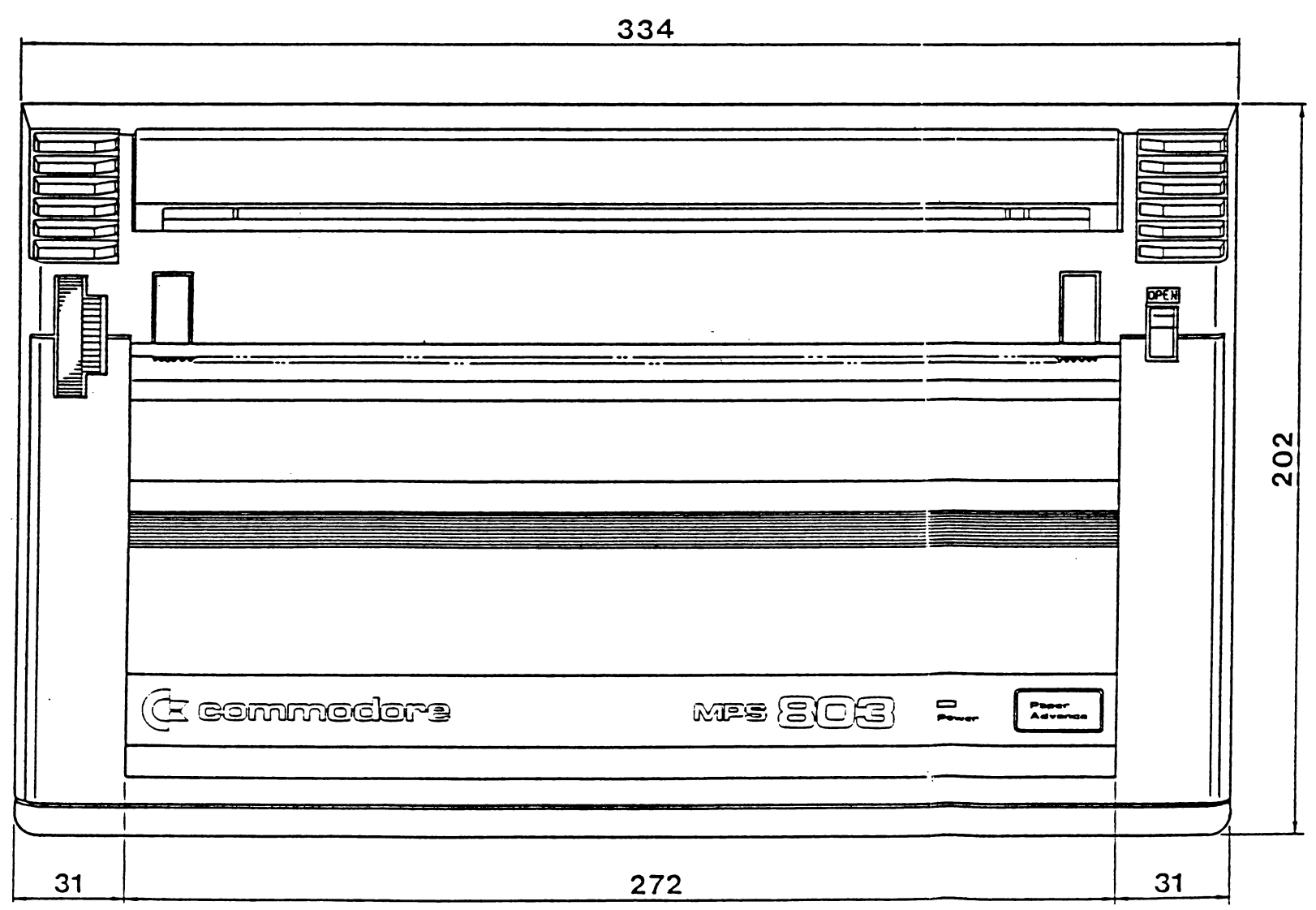
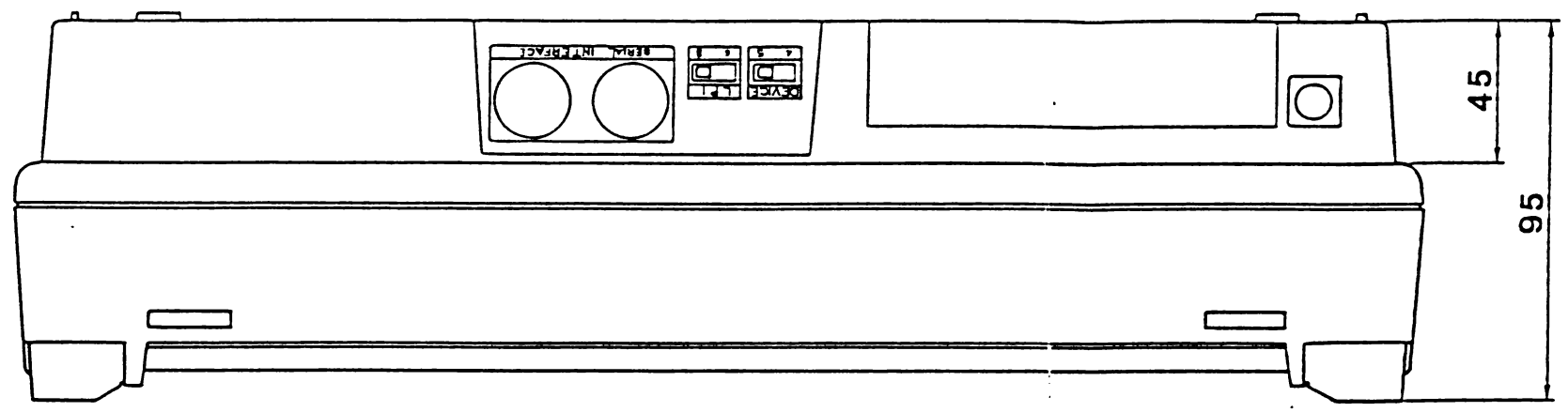

CHAPTER 2
OPERATION

I. Precautions

1. Wait at least two seconds to turn on the power after it is turned off, otherwise the Printer will not be initialized properly.
2. Never place the Printer where it is exposed to direct sunlight.
3. Never apply power while you are plugging in or unplugging an input connector.
4. Never turn off the power while the Printer is in motion.
5. Never try to move the print head manually, whether the power is on or off.
6. Do not stop the print head motion while it is printing.
7. Do not print without paper and/or ribbon because the print head might be damaged.
8. Turn off the power quickly and remove a foreign object, if you drop it into the printer.
9. Do not subject the Printer to temperatures below 5°C or above 40°C during operations, or to a sudden change in temperature.
10. Regarding printing duty:
In graphic mode, using patterns with too much dot density will wear out the print head faster. We recommend that you use patterns whose dot density is equal to that of ordinary alphanumeric. The continuous printing of high dot density patterns may adversely affect the longevity of the print head.
11. Unplug the power cord before trying to take off the outer casing.
12. Do not turn ON/OFF your printer while the system is in operation.

II. Parts identification

Shown below are the names of parts of the printer.

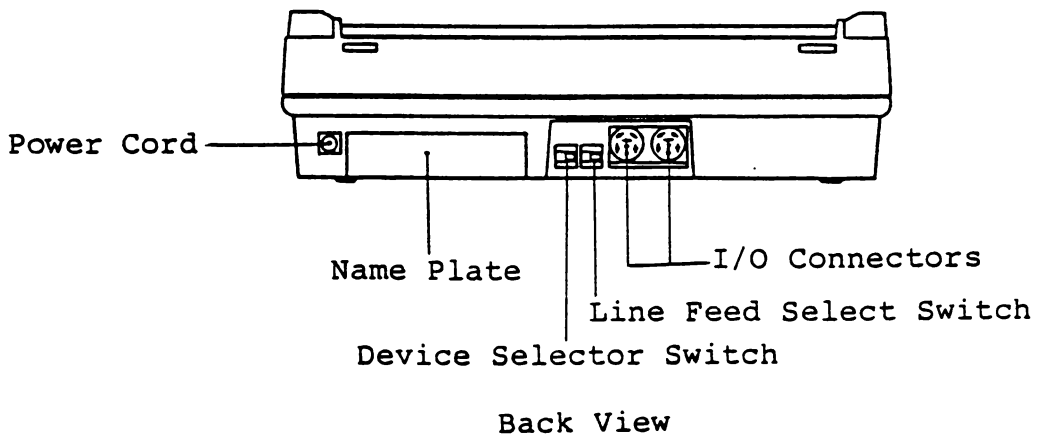
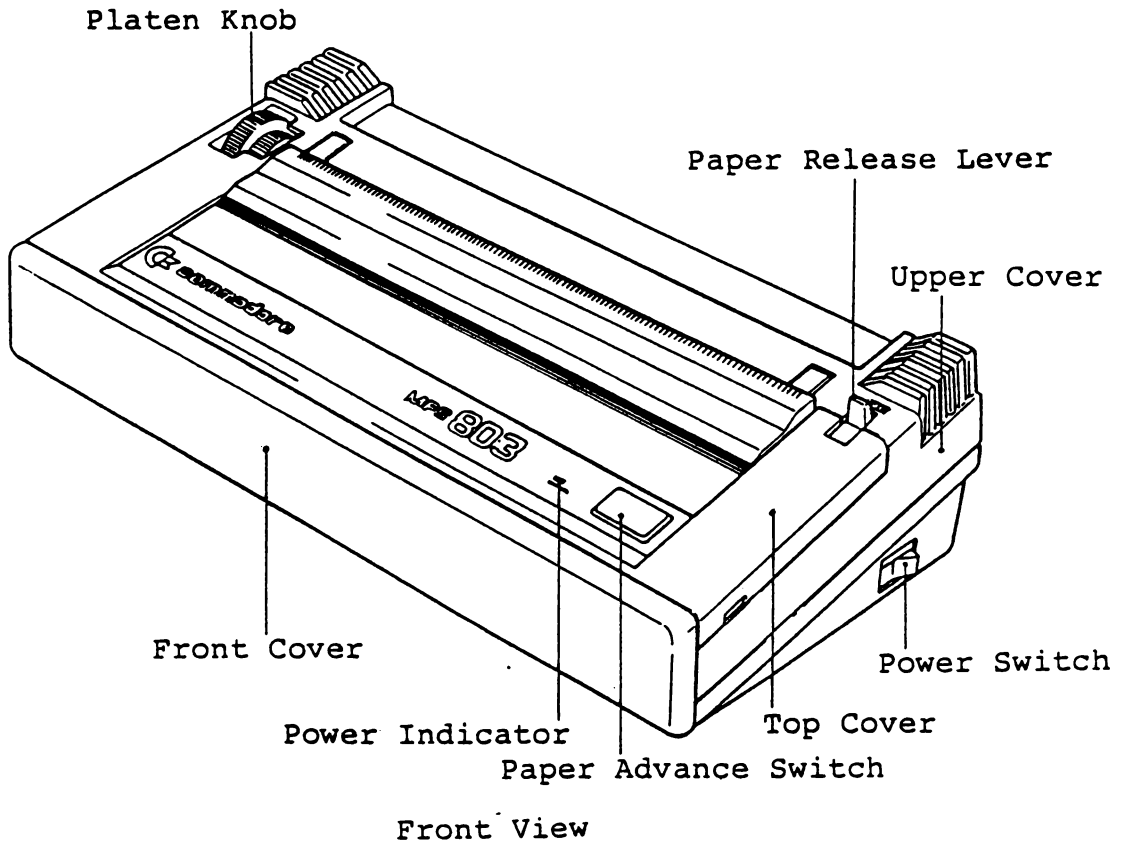

III. Operating functions

1. Power Switch Turns printer ON and OFF
2. Paper Release Lever Releases paper in order to adjust paper in right position.
3. Platen Knob Once you have properly threaded the paper, you can use the Paper Feed Knob to move the paper (both forward and backward directions).
4. Switch Panel

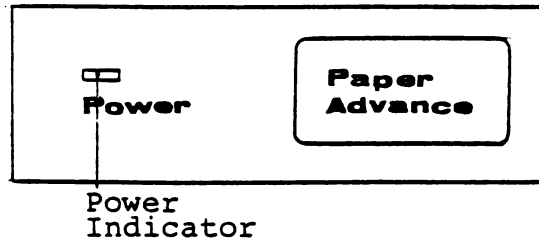

- a. Paper Advance Switch Use this switch to move paper ahead, 1 line at a time, in the forward direction only. And self-printing starts when power is turned on with this switch depressed.
 - b. Power Indicator Lights up when printer is turned on.
5. I/O connectors These jacks are used to connect your Printer to the computer. Use the Serial Interface cable supplied with Printer. Refer to Section 10 for complete connection instructions.

a-1 The Connector

Pin No.	Signal
1	SERIAL SRQ
2	GND
3	SERIAL ATN
4	SERIAL CLK
5	SERIAL DATA
6	RESET

a-2 The Interface

- * Plug the serial interface cable with your Printer into the Serial Bus connector for the connection. Refer to Section 10 for details on how to connect your Printer to your computer.
- * When the printer is printing, no data will be transferred from the computer (the data line is said to be low). When the printer is at rest, data can be transferred from the computer (the data line is said high).
- * When a printer error occurs, all control circuits inside the Printer will stop.

6. Line Feed Select Switch Use this switch to select the line feed

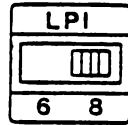

8: 1/8"
6: 1/6"

7. Device Selector Switch Select the device number 4.

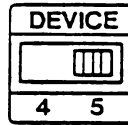

8. Power Cord Use the power cord supplied with your Printer.
9. Name Plate This plate describes Model Name required power source voltage, and acquired standards.
10. Connecting the Printer to Your Computer To connect your printer to your Commodore computer C64, please follow the figures below.

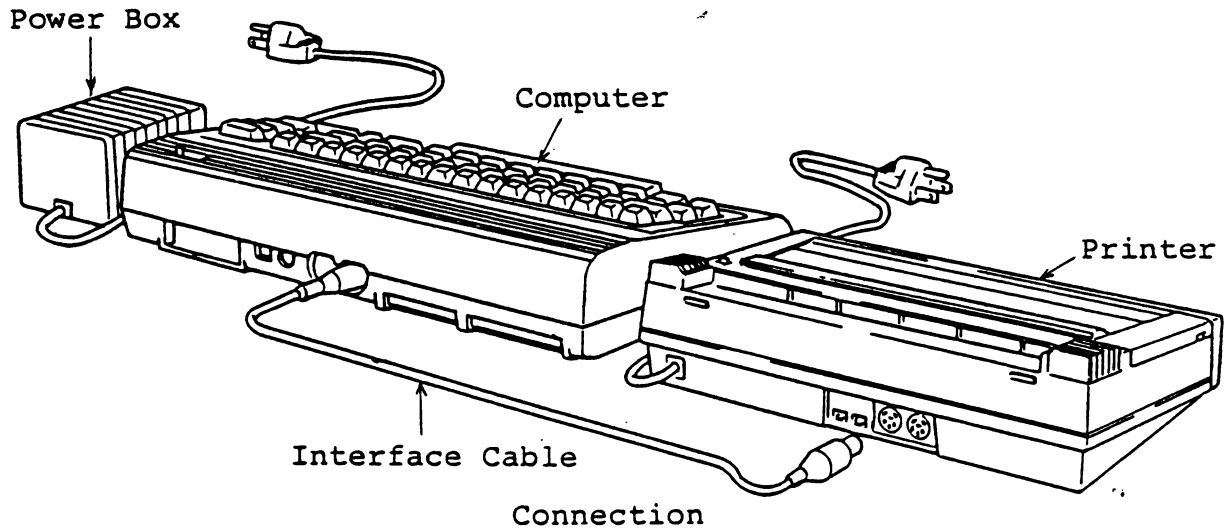

Your printer has two interface connectors. Please use either of them.

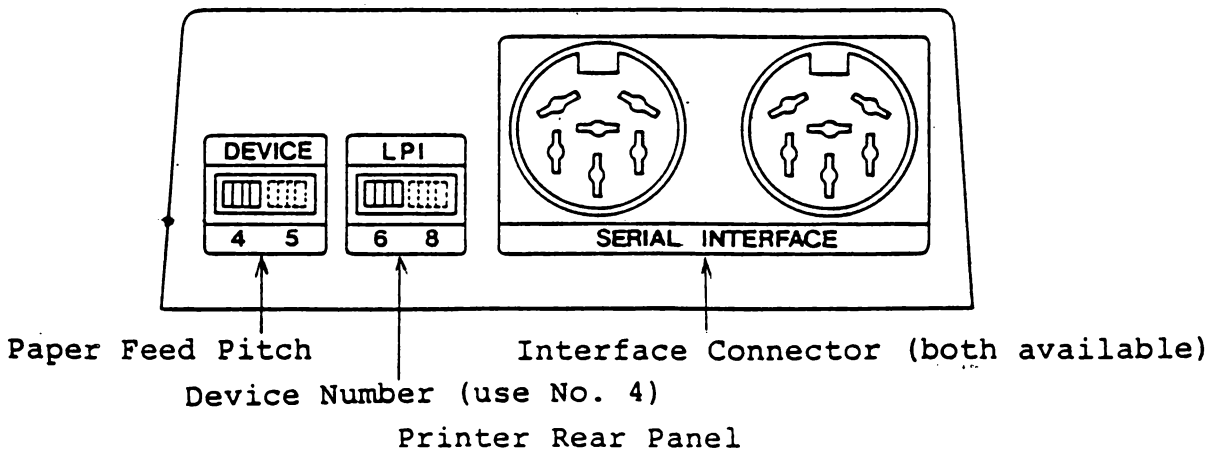

IV. Setting up

Follow the procedures below to set up the printer.

1. Installing the ribbon cassette.
 - a. Take out the ribbon cassette from the box.
Turn the ribbon advance knob into the direction of arrow to stretch the ribbon.

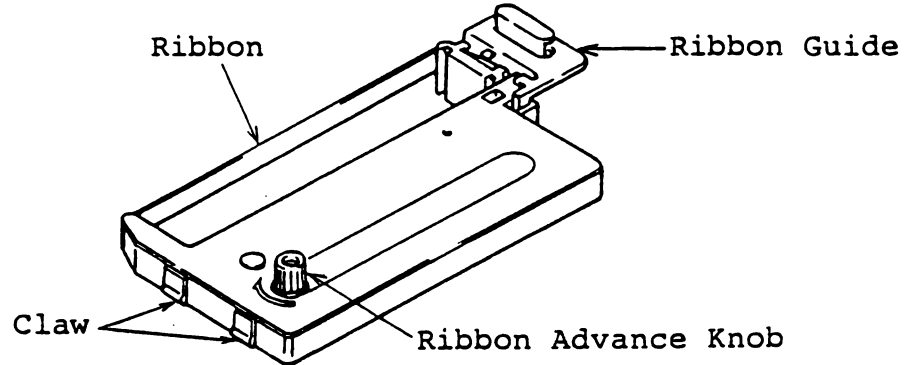

- b. Remove the top cover.
Lift both side ends and pull into the direction of arrow.

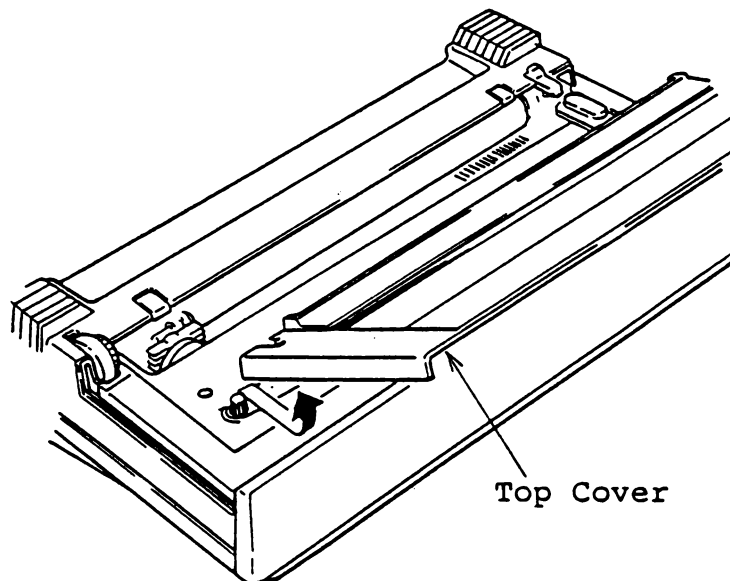

- c. Slip the ribbon in between the carriage and print head. Install the cassette to the printer.
(Note) Make sure the ribbon is not twisted.

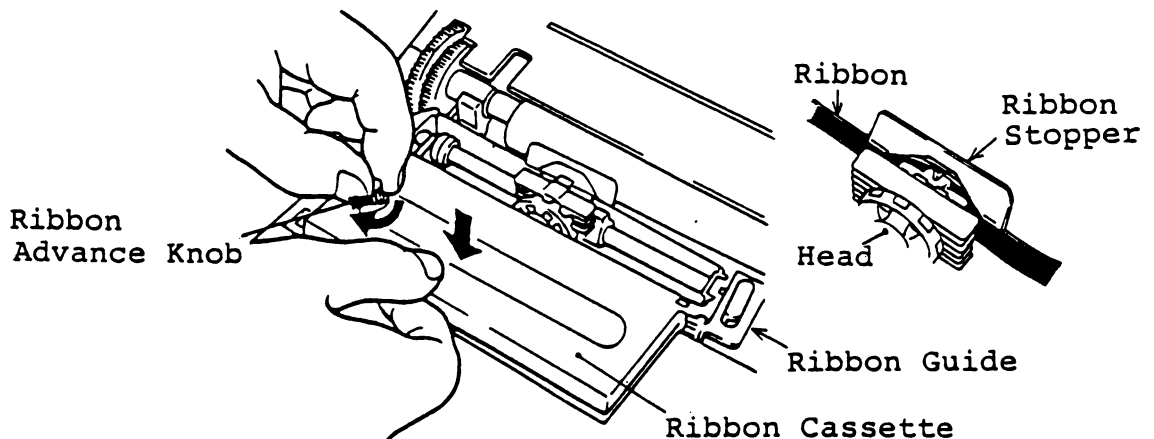

- d. Hook the ribbon on the ribbon stopper and pull right the ribbon guide slowly and horizontally and fix it to the printer body.

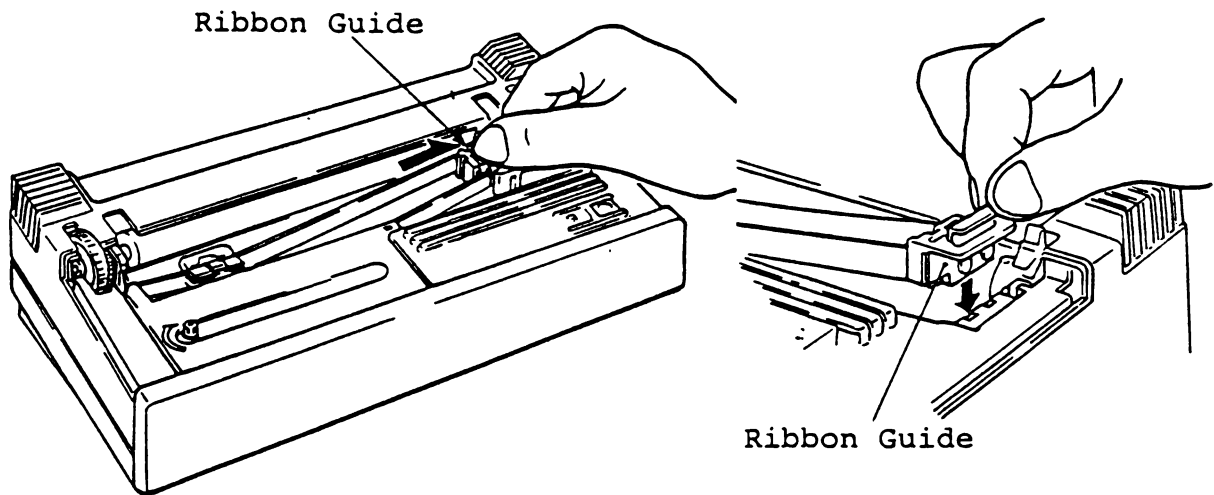

- e. Turn the knob into the direction of arrow to stretch the ribbon.
 (Note) Make sure the top end of the ribbon is engaged in the ribbon stopper.

Ribbon Advance Knob

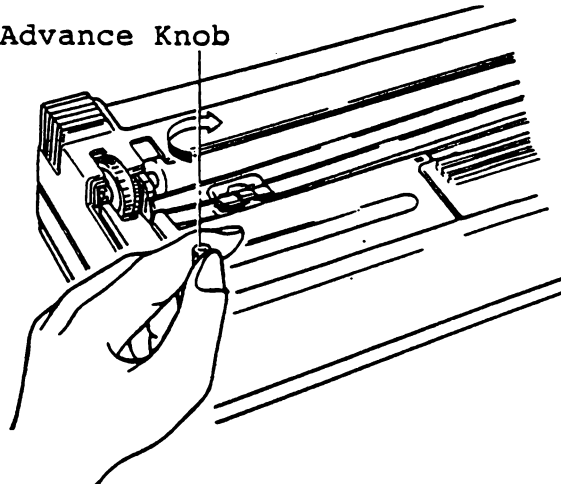

- f. Attach the top cover.

2. Loading the paper

(1) Cut sheet loading

- a. Push the paper release lever to OPEN.
- b. Insert the paper into the direction of arrow.

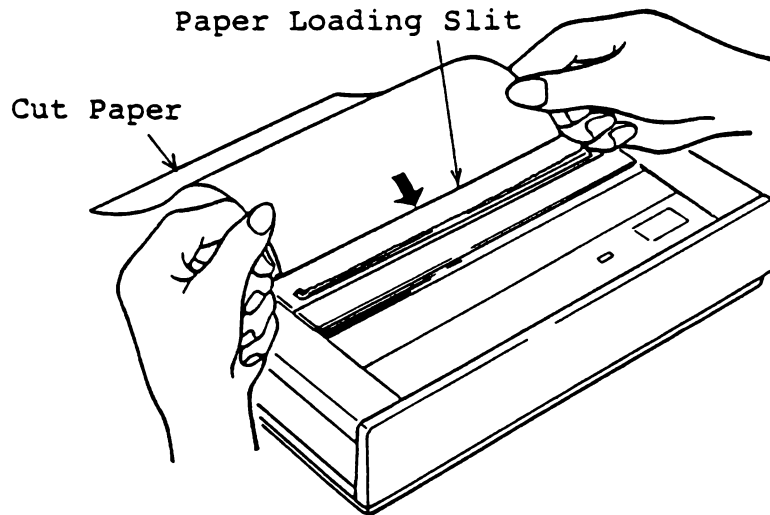

- c. Pull the paper release lever into the direction of arrow.

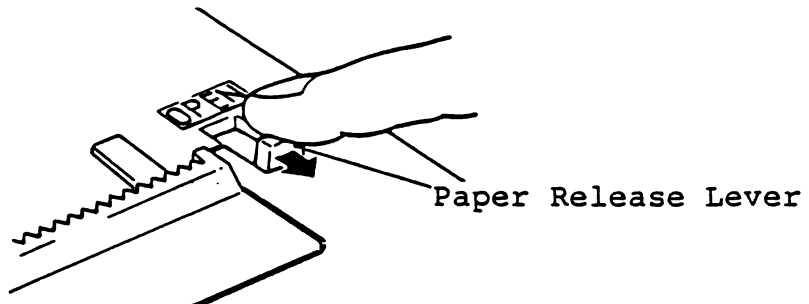

- d. Turn the platen knob as shown until the paper comes out from the window cover.

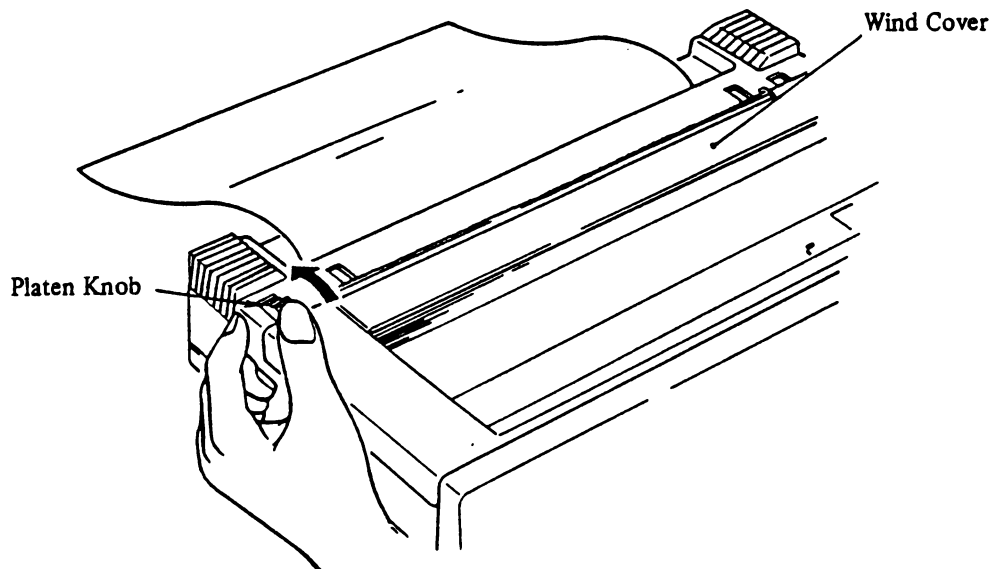

- e. Push the paper release lever to OPEN.
Hold the paper and make the edges parallel.
Then set paper release lever to the closed position.

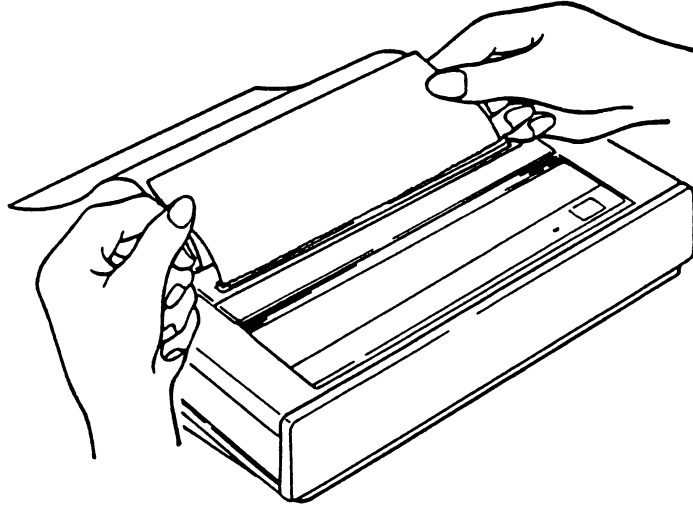

- f. Turn backward the platen knob and set the paper to the print start position.

- (2) Tractor unit (optional)
- a. Remove the top cover. Remove the cover caps by pulling them forward.

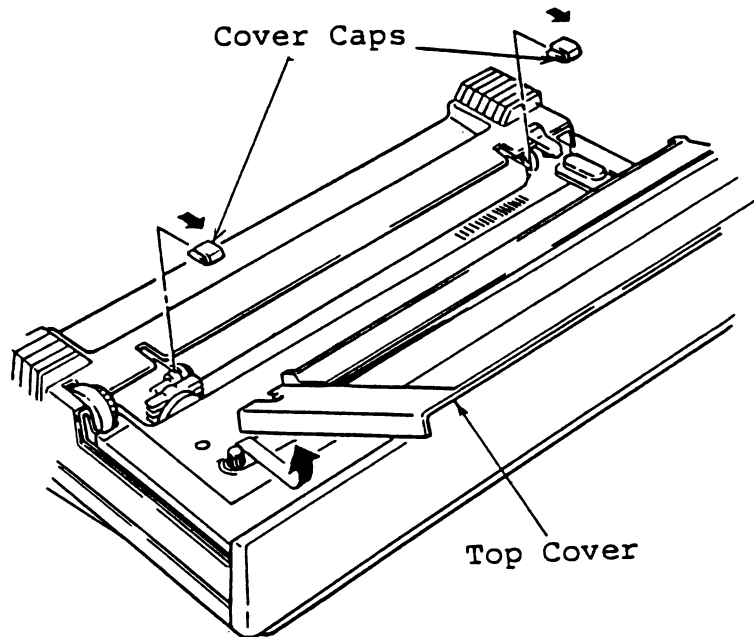

- b. Insert the front hooks of the tractor unit into the holes located at the upper end of the top cover and securely fix the unit onto the platen shaft. Engage the rear hooks with the holes on the back of the printer.

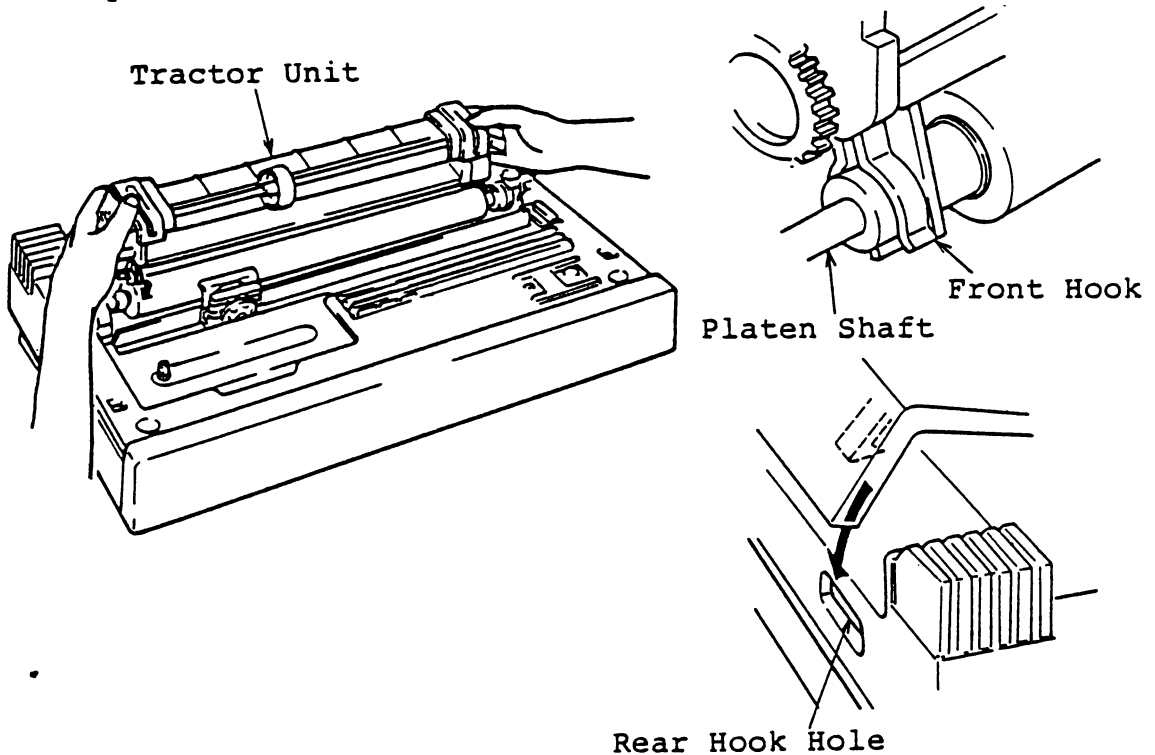

- c. Insert the fanfold paper into the paper loading slit. Turn the platen knob and feed the paper.

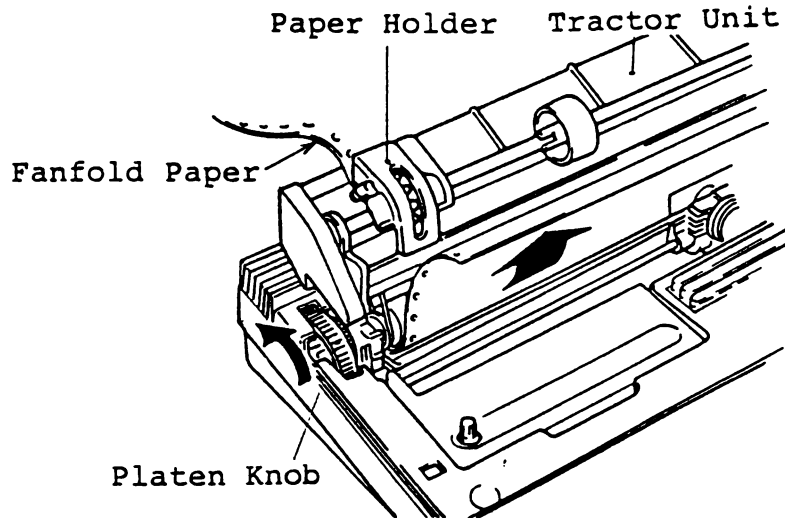

- d. Adjust the sprocket position to fit the paper width. If the sprocket pins do not engage with the sprocket holes, move the paper holder to fit. Put down the paper holder cover and push the paper release lever to OPEN.

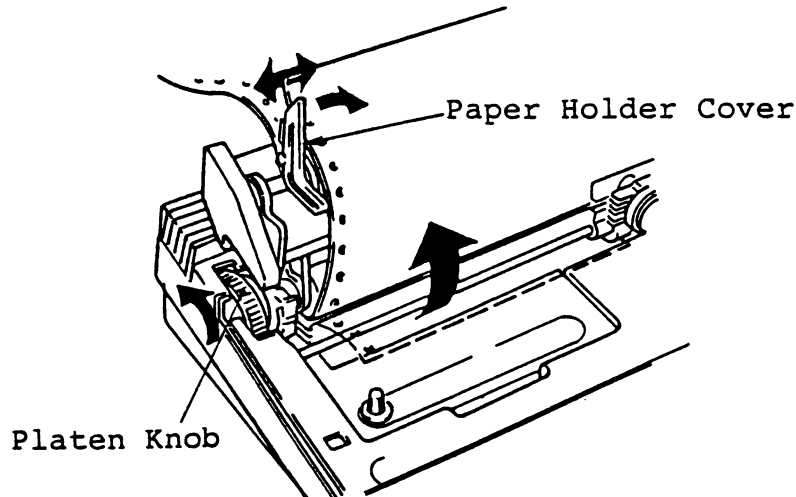

- e. Turn the platen knob and set the paper to the print start position.

Note 1) After the paper setting, press the paper advance key and feed the paper for one line. (This is to avoid irregular spacing between the 1st and 2nd lines.)

Note 2) Always set the paper release lever to OPEN. Set the lever to CLOSE when the tractor unit is not provided.

3. Performing the Printer Power On Test

You are now ready to proceed with the power-on part of the checkout.

- (1) Turn on the AC power to your computer and verify that is working correctly.
- (2) To turn on the power to the printer, press the rocker switch at the side of the printer so that the white dot is visible. In response to the application of AC power, POWER light in the PAPER ADVANCE switch should be lit and the printer's microprocessor should move the print head all the way to the right, then to the home position at the far left. If this does not happen (and that's highly unlikely), turn off both machines, check all connections and try again. If you still get no response, contact your Commodore dealer.

4. Diagnostic Print Test

Now you can perform the diagnostic print test of the print head and the ribbon cassette as well after you have inserted the paper. Never allow any printing to occur when there is no paper in the printer. If paper empty occurs, the power/error indicator flashes. Please install paper and then press the paper advance switch to cancel paper empty status.

To perform the diagnostic print test, simply turn off the printer and then turn on again while pressing the Paper Advance Switch.

CHAPTER 3
OPERATING PRINCIPLE

Operating principle

1. Printing mechanism

The impact wire dot system is employed

Print head contains 8 solenoids circularly positioned on the core frame, armature print wires operated by the solenoids and wire guides. The 8 print wires are precision located by the guides on top.

Printing is executed when the carriage travels at the printing speed, the character generator sends the print command pulses to the driver to operate the solenoids which push the print wire through the armature onto the ink ribbon finally onto the printing paper. Print timing is controlled by the drive pulse of the pulse motor which drives the carriage. A standard character is made with 7 x 5 dot matrix. The 8 solenoids are selectively activated in each column according to the print data in ROMs. The print wires return to the original position by spring force after the solenoid operation. Printing is bi-directional.

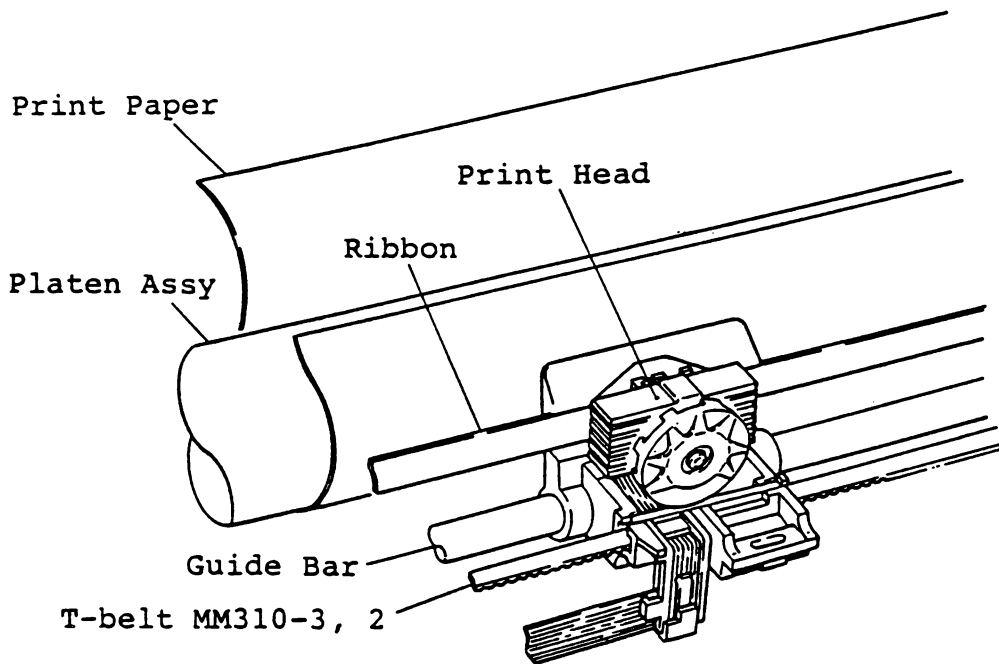

2. Carriage drive mechanism

Revolution of the CR motor is transmitted to the C drive pulley through the motor gear.

The C drive pulley and the carriage idle pulley are connected with the T-belt MM310-3.2 which is fixed to the carriage with a holding plate.

As the CR motor runs forward and reverse, the C drive pulley turns to move the T-belt and carriage right and left along the guide bar and frame plate.

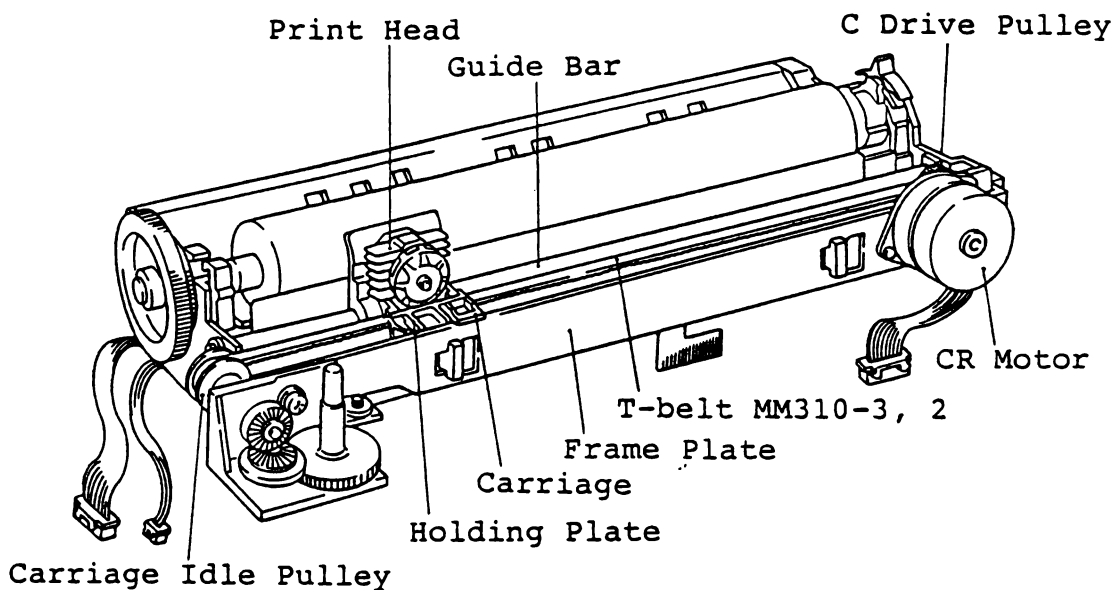

A leaf switch is mounted on the left end of the frame. When this switch is pushed by the projection provided to the carriage, the carriage 0 position is detected.

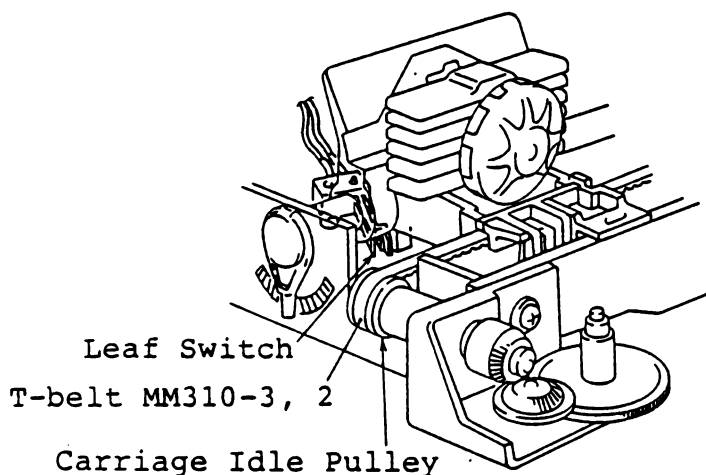

3. Paper feed and release mechanism

(a) Paper feed mechanism

Revolution of the LF motor is transmitted to the platen knob gear through the LF idle gear.

Platen is coupled with the platen knob so that it turns as the LF motor does.

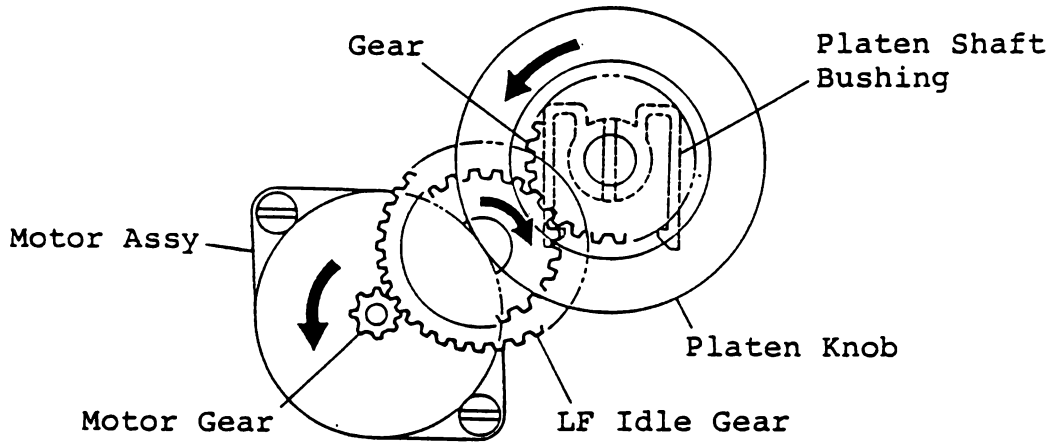

PF roller assy is built right under the platen. Three roller retaining springs are used to hold three roller assys on the platen. Paper is caught between the platen and the roller and fed as the platen turns.

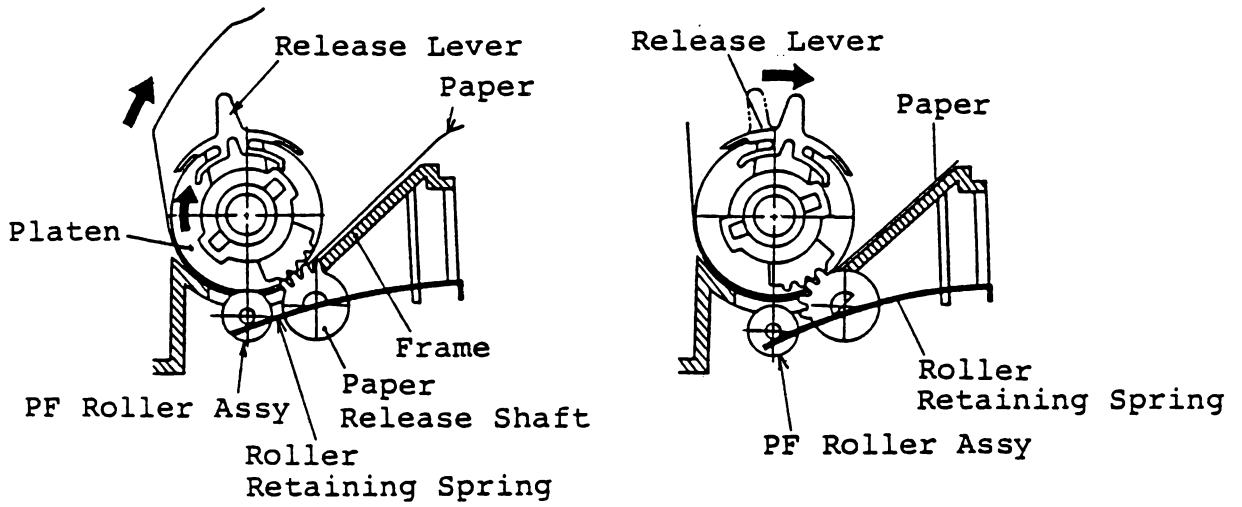

(PAPER FEED CONDITION)

(PAPER RELEASE CONDITION)

By pressing once the LF key in the OFF LINE status (when the ON LINE lamp is off), the paper is fed for one line. By keeping on pressing it, the paper is continuously fed.

(b) Paper release mechanism

By setting the release lever to OPEN, the paper release shaft turns through the gear. The roller retaining spring is released and the platen detaches from the PF roller assy. (PAPER RELEASE CONDITION) In this condition, paper position can be corrected.

(c) PE switch

PE switch detects the presence of the printing paper. When the paper is being set, the PE switch actuator is pushed down for printer operation. When the paper has run out, the PE switch actuator moves away upward to detect the PE condition. Then the ERROR status turns on and the printer stops.

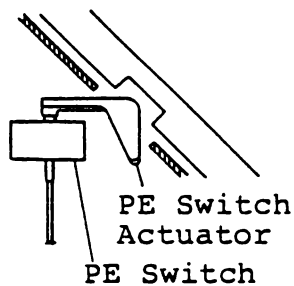

(Paper Empty)

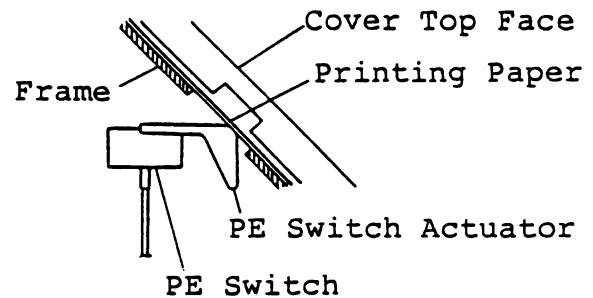

(Paper is set)

4. Ribbon feed mechanism

Revolution of the CR motor is transmitted to the carriage idle pulley through the motor gear, C drive pulley and T-belt MM310-3.2. And then, to the ribbon drive gear through the idle pulley shaft secured to the idle pulley and the ribbon idle gear. A spring clutch is mounted on the idle pulley shaft and the ribbon drive gear shaft so that the revolution is performed into FORWARD direction (when the carriage moves from left to right)

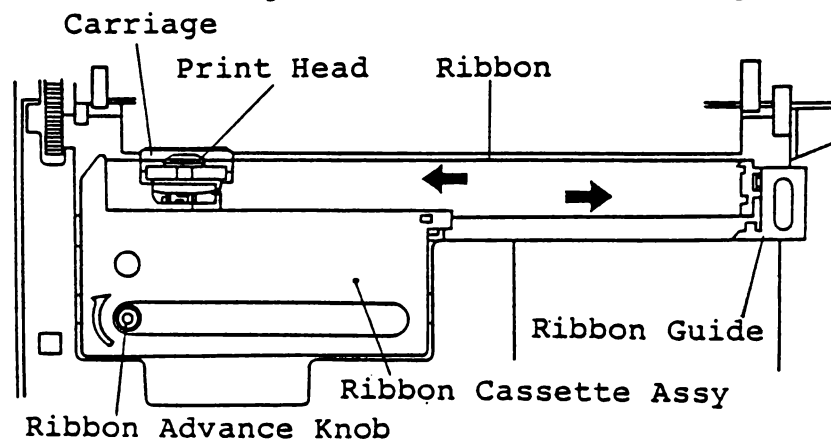

When the ribbon cassette assy is mounted to the mounting part of the body cover, the ribbon advance gear A of the ribbon cassette assy engages with the ribbon drive gear. As the ribbon advance gear A turns, the ribbon advance gear B turns and the ribbon advances. Ribbon tension is built in the ribbon cassette assy to provide proper tension to the ribbon.

II. Operation of the electronic parts
 1. Structure

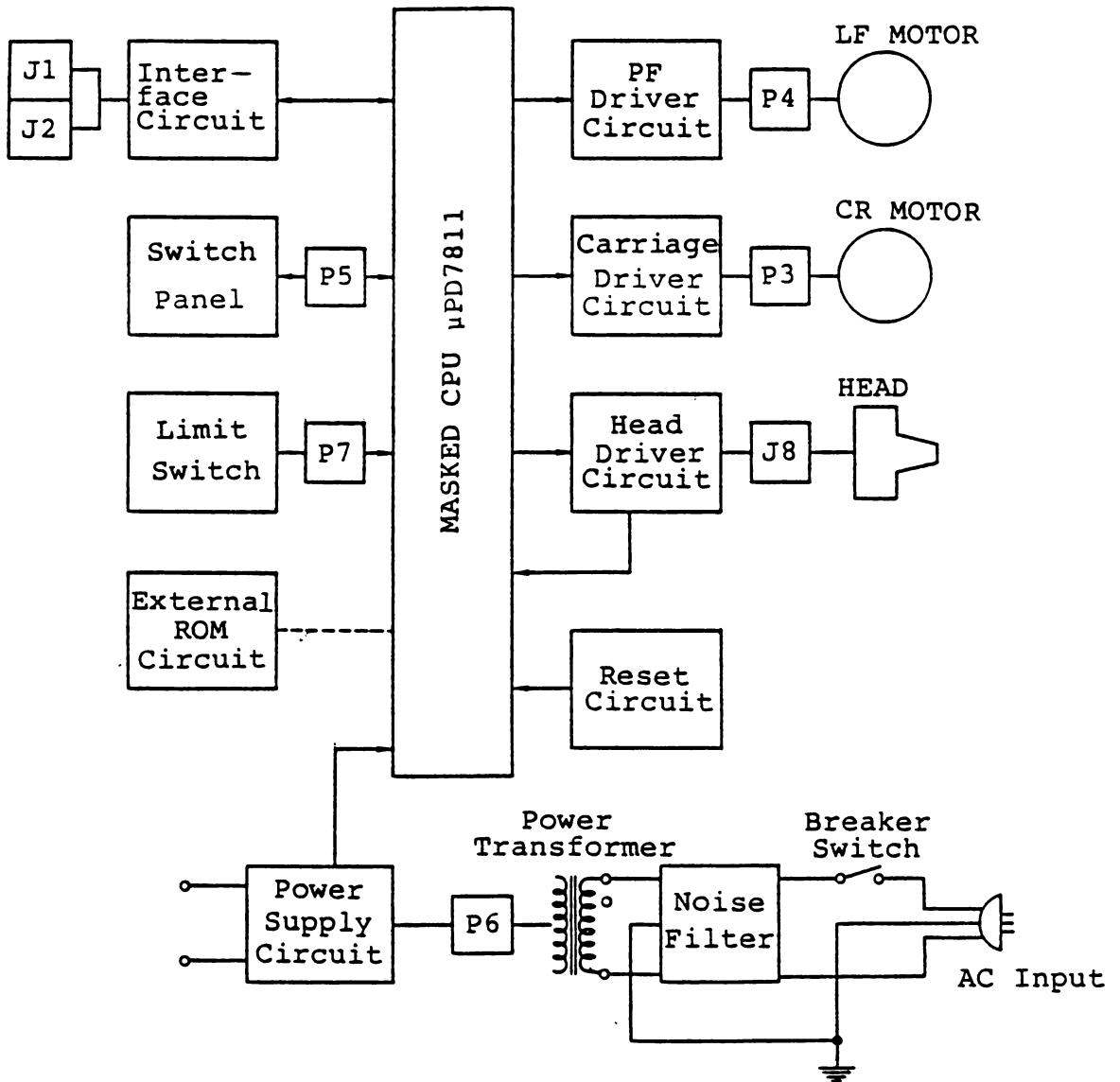

° P3, J8, etc. are the connector Nos. on the logic card.

2. CPU

μPD7811(NEC) is used for the CPU. Contains a 4K byte ROM and a 256 byte RAM. Pin connections are shown below.

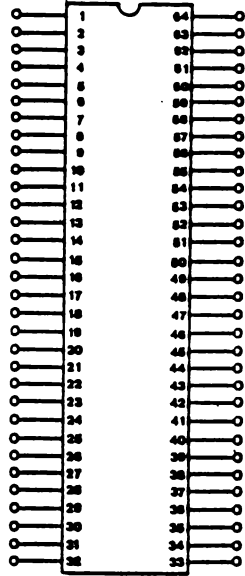

- PA7-0 : Port A
- PB7-0 : Port B
- PC7-0 : Port C
- PD7-0 : Port D
- PF7-0 : Port F
- NMI : Non Maskable Interrupt
- INT1 : Interrupt Request
- MODE0 : Mode0, 1
- X1, X2 : Crystal
- ANT-0 : Analog Input
- \overline{RD} : Read Strobe
- \overline{WR} : Write Strobe
- ALE : Address Latch Enable
- \overline{RESET} : Reset
- VAREF : Reference Voltage

The control program and the CG ROM are masked in the 4K byte ROM in the CPU. MODE 1 and MODE 0 terminals are fixed to 'HIGH' and 'LOW' respectively. The analog input terminal functions to convert the analog input of 0V - + 5V into 8-bit digital data. * See Section 7 for the addition of PROMs.

3. Interface circuit

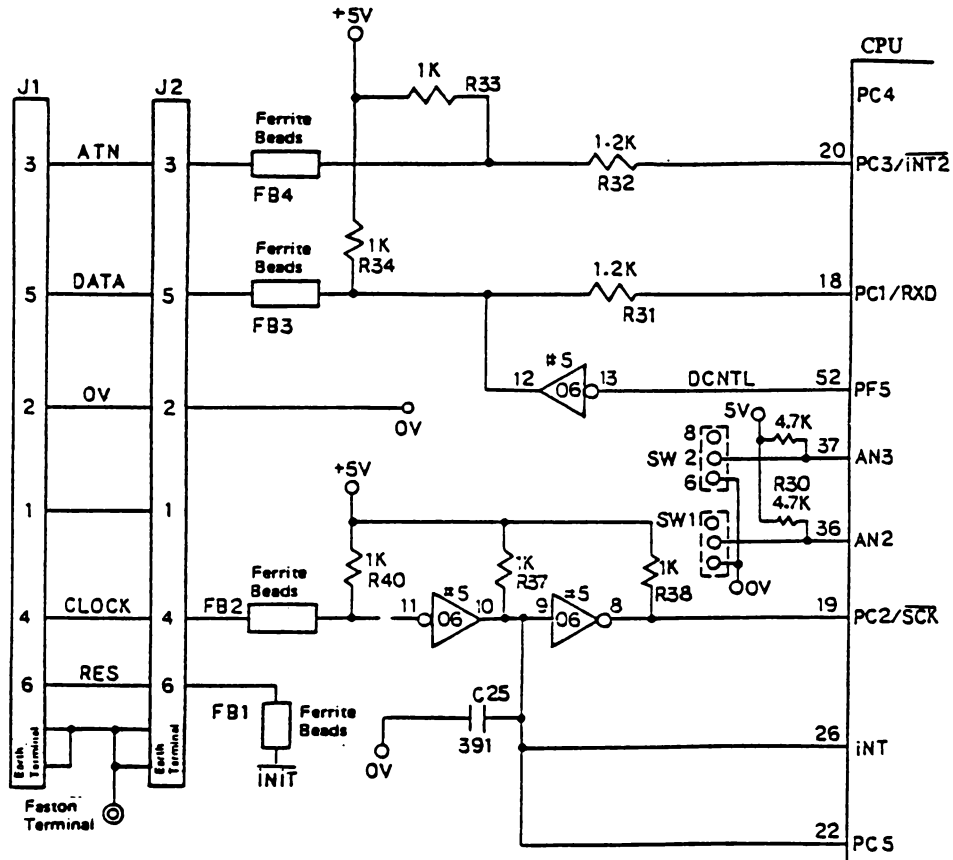

Connectors J1 and J2 are the DIN connector for interface and each connected in parallel.

DATA LINE is the serial 8-bit data and sampling is done by the CLOCK LINE.

ATN LINE selects data for control ($\overline{\text{ATN}}$ = 'LOW') and for ordinary data ($\overline{\text{ATN}}$ = 'HIGH'). $\overline{\text{RES}}$ LINE is used for resetting the printer. Resetting is done in the same way as when power is first turned on.

The CPU operates with the synchronous serial input mode made up with the DATA input port PC1/R x D and the CLOCK input port PC2/ $\overline{\text{3CK}}$. PC3/ $\overline{\text{INT2}}$, INT1 and PC5 are the input port and PF5 is the output port.

INIT signal is a RESET input ($\overline{\text{RES}}$ LINE) from the interface and connected to the RESET circuit.

Faston terminal is connected to the F.G.(Frame Ground) and shields the interface cable.

Interface timing conforms to the CBM Serial Interface.

Data reception timing is described in the following:

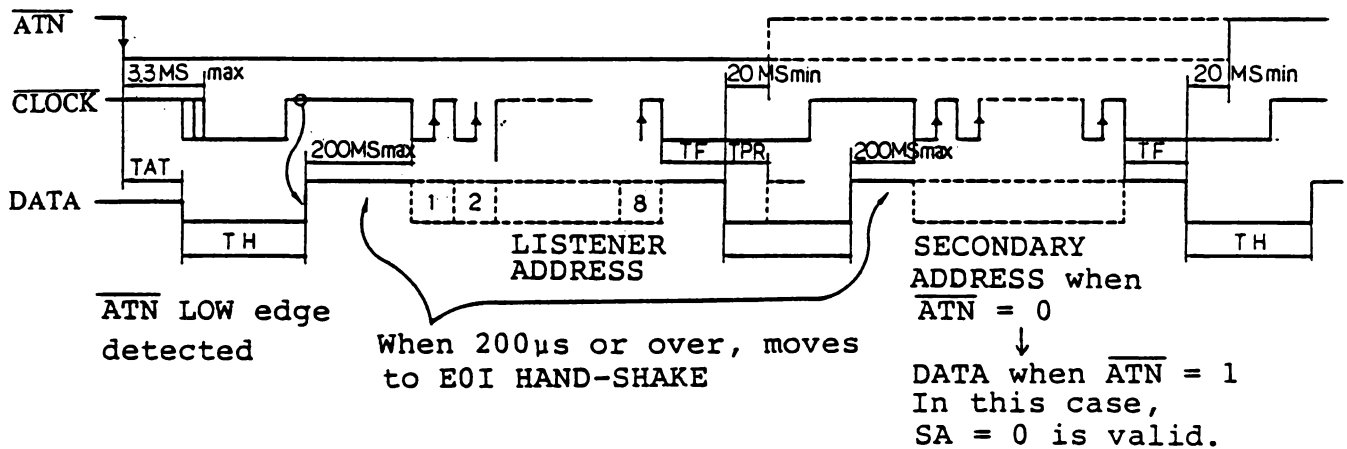

- ° After 3.3ms or over from $\overline{\text{ATN}}$ edge, $\overline{\text{CLOCK}} = 1$ is detected and DATA is set to "HIGH". (at L.A.(LISTENER ADDRESS), UNL reception)
- 1. $\overline{\text{ATN}} = 0$ is referred to the LISTENER ADDRESS, SECONDARY ADDRESS and UNLISTEN (UNL).
- 2. TH is equivalent to BUSY. If requesting NEXT DATA, wait for $\overline{\text{CLOCK}} = 1$ and set DATA to 1. In the case of SYSTEM LINE-RELEASE, DATA is set to 60 - 80μs "LOW" without regard to CLOCK. SYSTEM LINE-RELEASE: LISTENER ADDRESS Not identified
- 3. TAT = 1ms max. TF = 20 - 1000μs

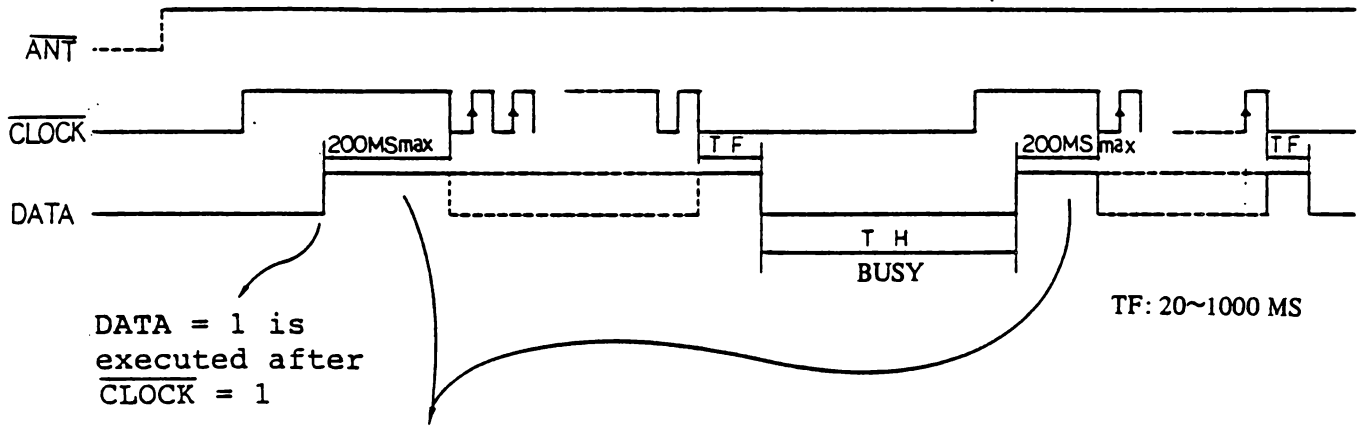

When 200µs or over, moves to EOI-HAND SHAKE.

When TH represents BUSY and the next DATA is requested, DATA = 1 is executed after CLOCK = 1.

4. Switch panel

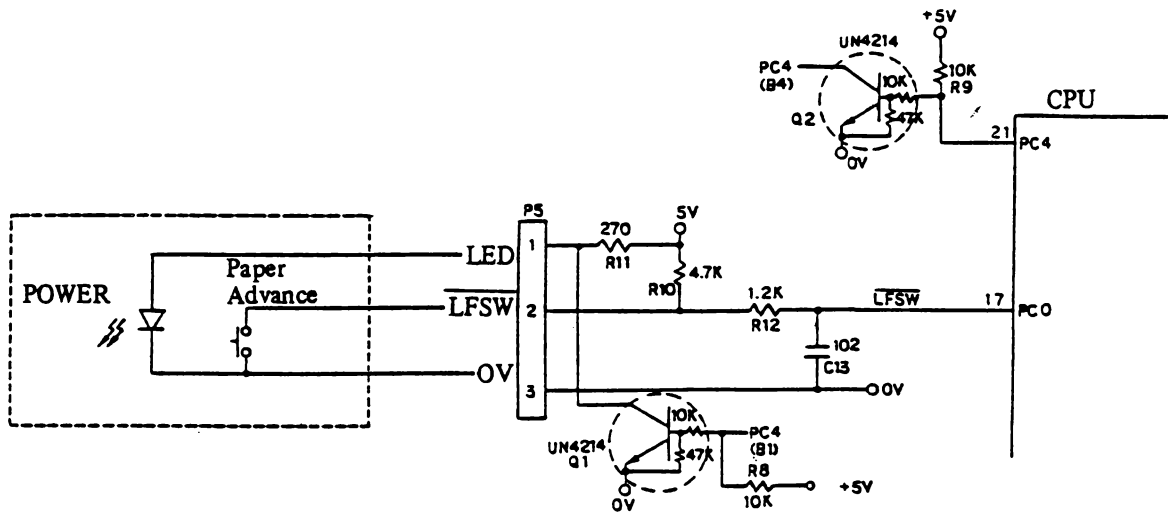

CPU port PC0 is an input port. By pressing the PAPER ADVANCE switch, LFSW signal is set to 'LOW', which executes one line feed. When 'LOW' status is maintained for about 0.5 second, the CONTINUOUS LINE FEED mode turns on. This is maintained until LFSW signal changes to 'HIGH'.

CPU port PC4 is an output port and is normally set to 'HIGH'. This port is used to flicker the POWER LED.

Flickering frequency:

PE detection	2.5 times/sec
MOTOR ERROR	10 times/sec

5. Limit switch

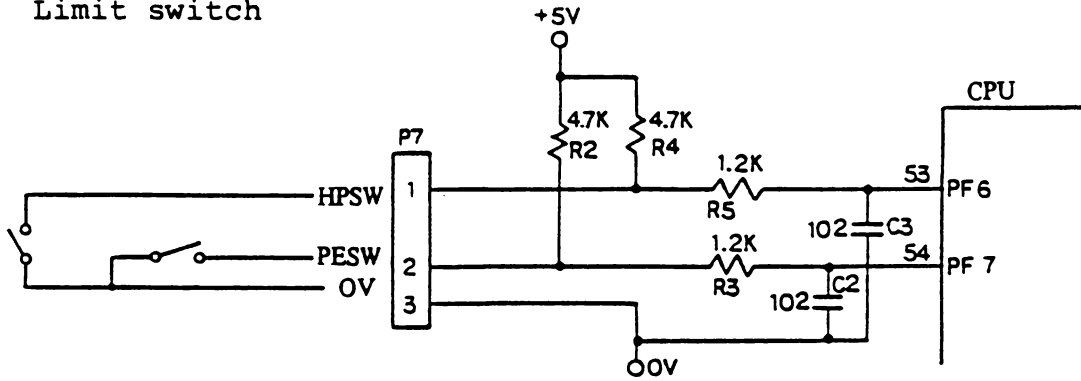

$\overline{\text{HPSW}}$ signal turns to 'LOW' at CARRIAGE LEFT END detection.

PESW signal is set to 'HIGH' at PE detection.

At POWER ON or RESET, the internal ROM is checked. If normal, the carriage is moved to the left end. If the time, takes longer than specified to LEFT END detection, MOTOR ERROR occurs. If LEFT END detection is correctly done, the carriage is moved to the center. If LEFT END detection still continues, MOTOR ERROR occurs.

Actual PE processing is executed at 3 lines after the PESW signal has turned to 'HIGH' status. PE detection is executed right before the line feed and print start operations.

6. Function select switches

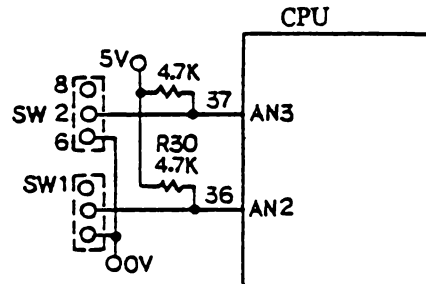

Switches SW1 and SW2 can be operated from outside together with the interface connector. SW1 is used to select the LISTENER ADDRESS (4 or 5). SW2 is used to select the amount of paper feed (1"/6 or 1"/8). SW1 is set to 4 and SW2, to 6, normally.

7. External ROM circuit

CPU is operating by the internal ROM of 4K byte. If necessary, an external ROM 14K byte can be used for the control. The following paragraphs explain the installation of external ROM.

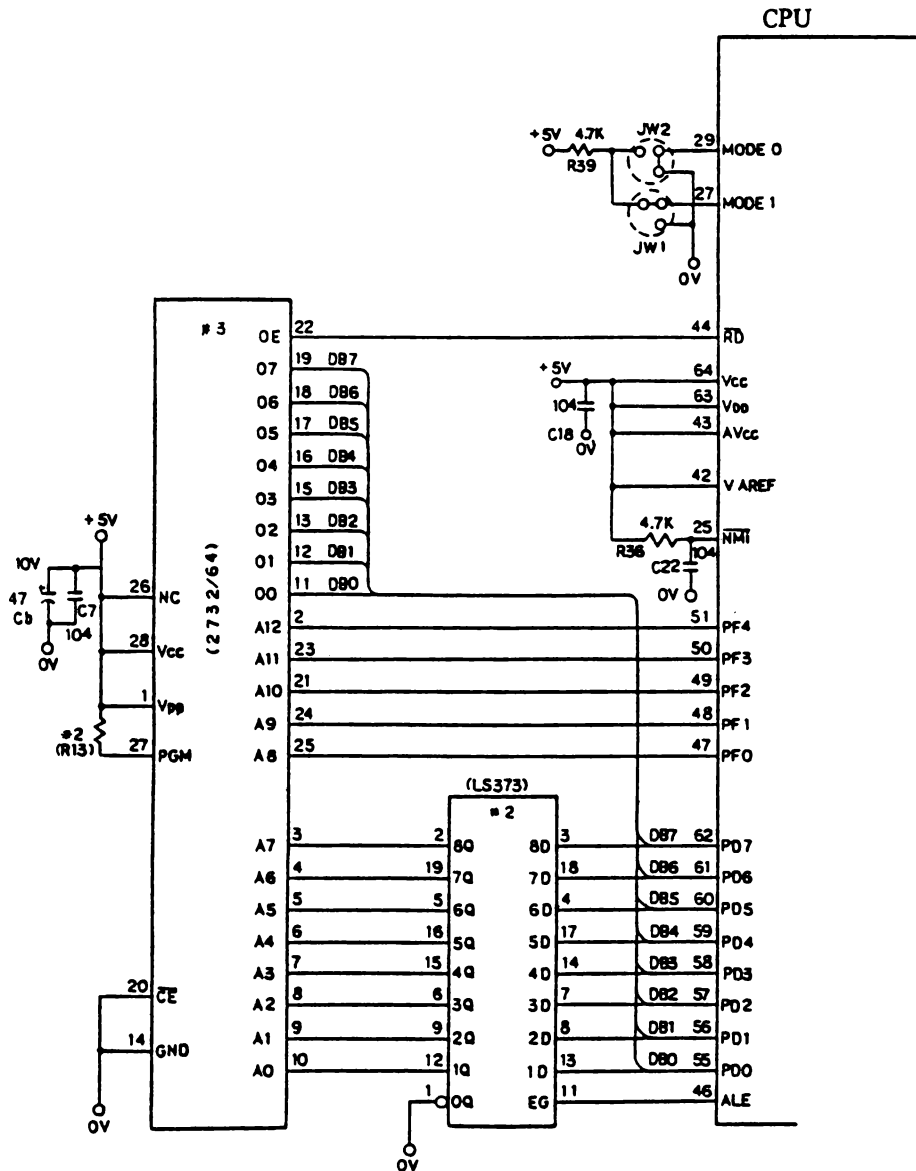

When the internal ROM is used, Mode 0 terminal is set to 'LOW' and MODE 1 to 'HIGH'. If the external ROM is to be used, MODE 1 terminal shall be set to 'LOW'.

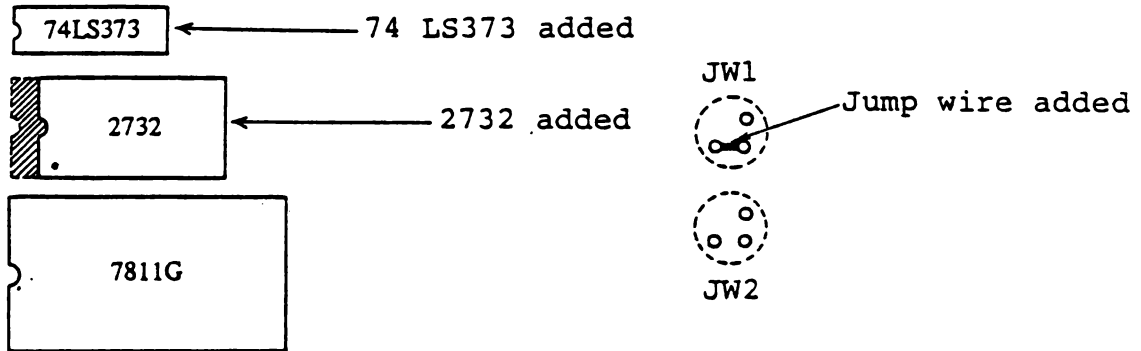

Above three additions enables the external ROM control.

8. Paper feed driver circuit

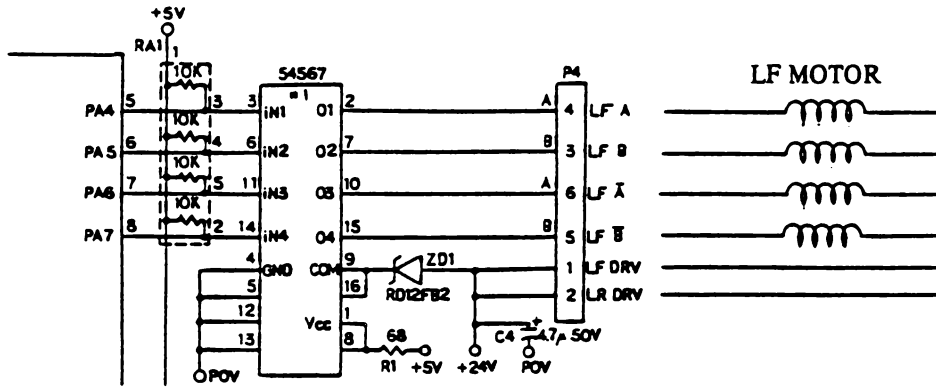

The LF motor is a step motor of PM type. It is stopped by the detent torque. Operated by 2-2 phase excitation. 1/216 per 1 step with the operating speed at 200 pps. 36 steps is necessary for 1"/6 feed.

\bar{B}	\bar{A}	B	A
1	1	0	0
0	1	1	0
0	0	1	1
1	0	0	1

Paper feed is executed by the excitation sequence shown on the left.

For driver IC M54567, second source TD 62308AP is sometimes used.

PIN CONNECTIONS

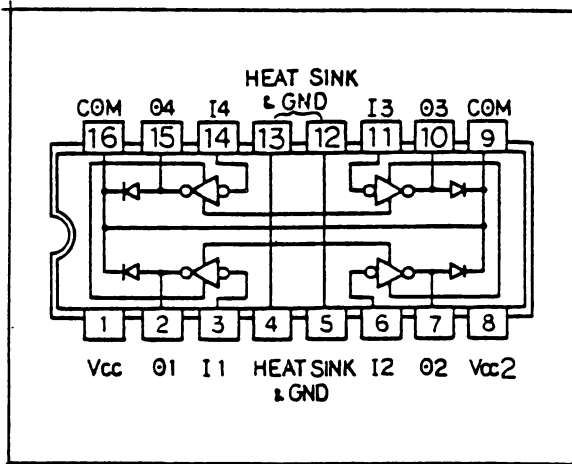

BASIC CIRCUIT

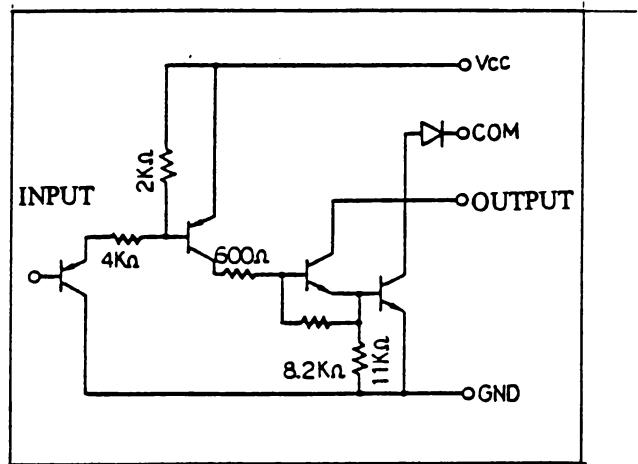

9. Carriage Driver Circuit

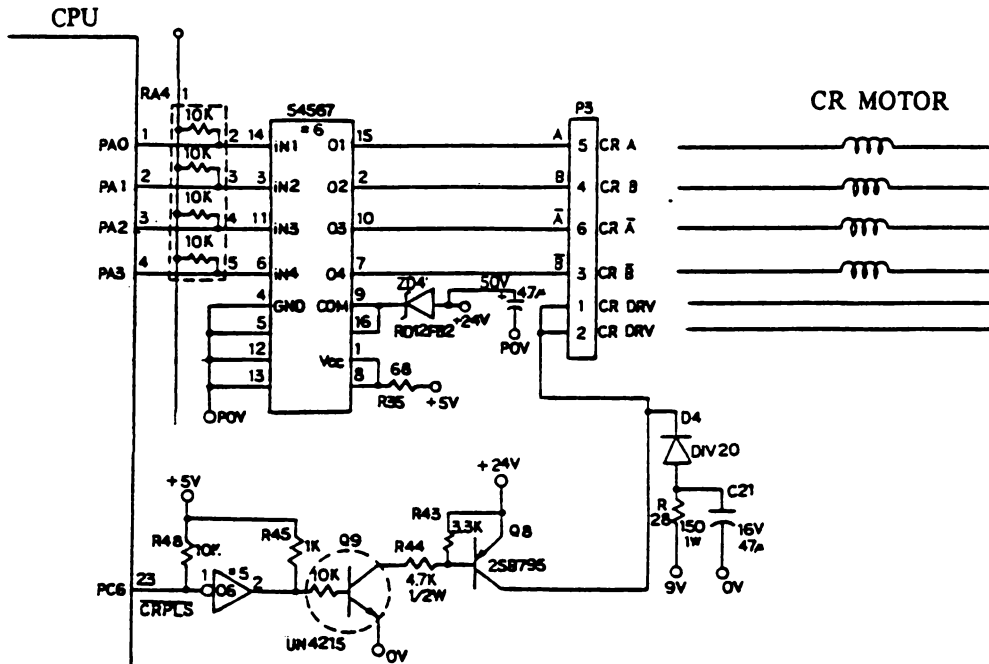

CR motor is a step motor of PM type. When stopped, CRPLS is set to 'HIGH' and is powered by +9V source for holding. Operated by 2-2 phase excitation. 1"/60 per 1 step with the operating speed at 360pps. The carriage reverses when the excitation sequence for the LF motor mentioned before is applied.

Basically performs 8-pulse SLEW UP/DOWN.

While running CRPLS is set to 'LOW' and the motor is supplied with +24V power.

Driver IC is same as that for paper feeding.

Pica size takes 1"/10 and is comprised of 6 steps.

10. Head Driver Circuit

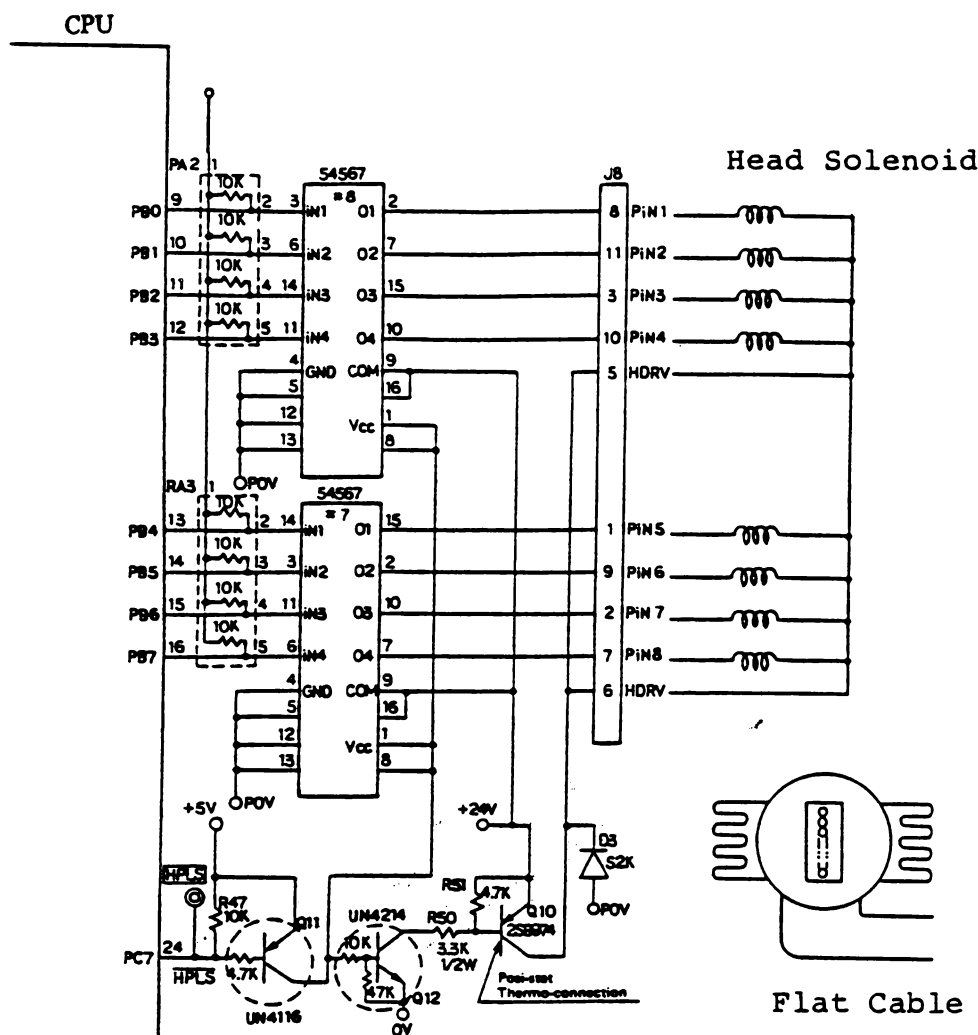

By setting data by negative logic to CPU ports PB0 - PB7 and by setting HPLS signal to 'LOW' for a required period, the head solenoid is driven. At the same time, Vcc terminal of the driver IC is also controlled. Therefore, the head solenoid transistors on the power source side and the ground side are always controlled together at the same time. Transistor Q10 on the power source side is provided with a thermo-sensitive resistance (PTH) which has a positive temperature coefficient. At about 60°C, AN1 signal reaches 2.5(V). While AN1 signal maintains 2.5V, BUSY is added after printing for about 0.5 second. This is to prevent overheat of the head.

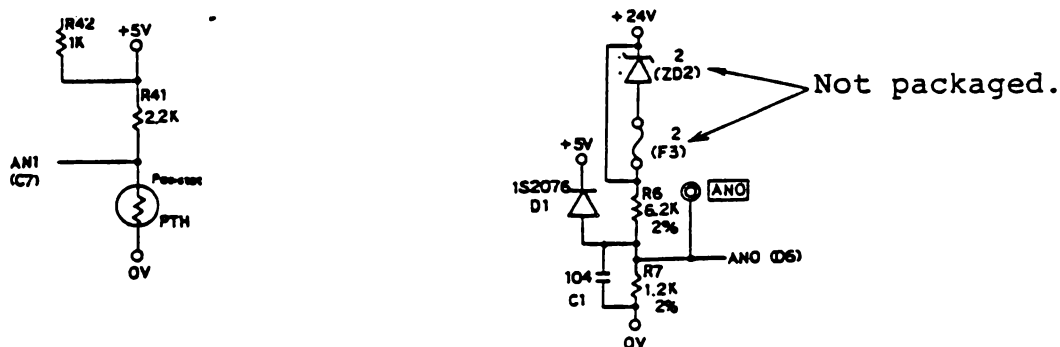

Since the +24V power source is not a stable power source, as described later, the head driving time should be properly controlled to stabilize print quality. ANO signal is used for this purpose, and is the voltage obtained by dividing +24V by resistance.

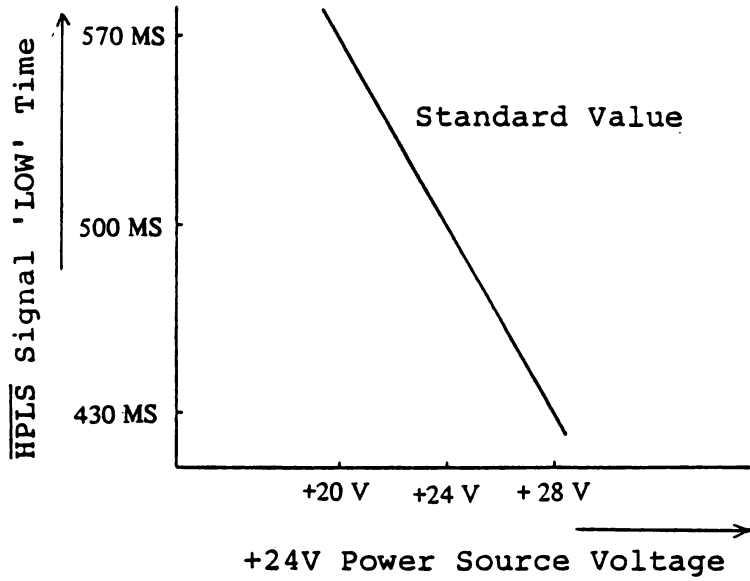

Adequate Pulse Width for +24V Power Source Voltage
Head Driving Timing Chart

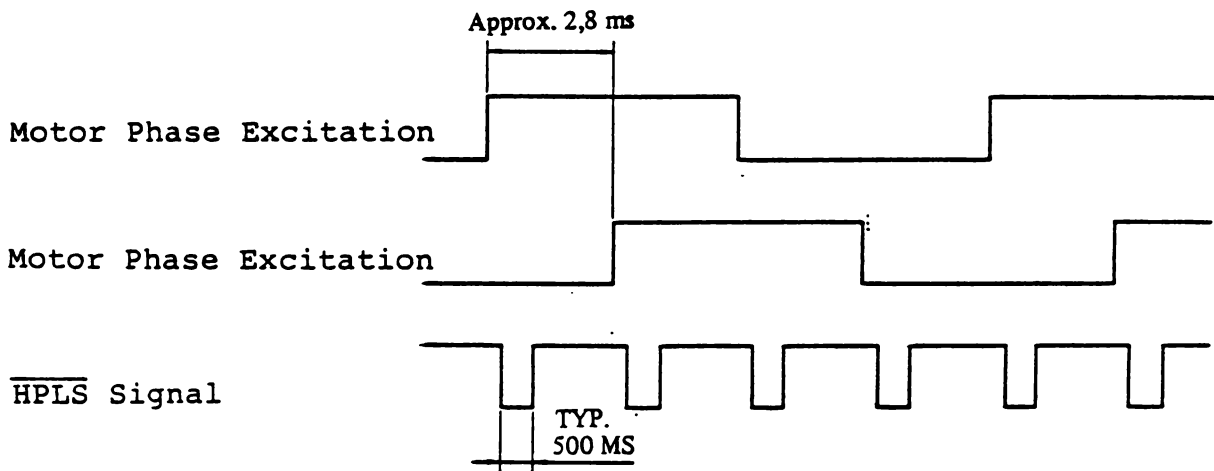

11. Reset Circuit

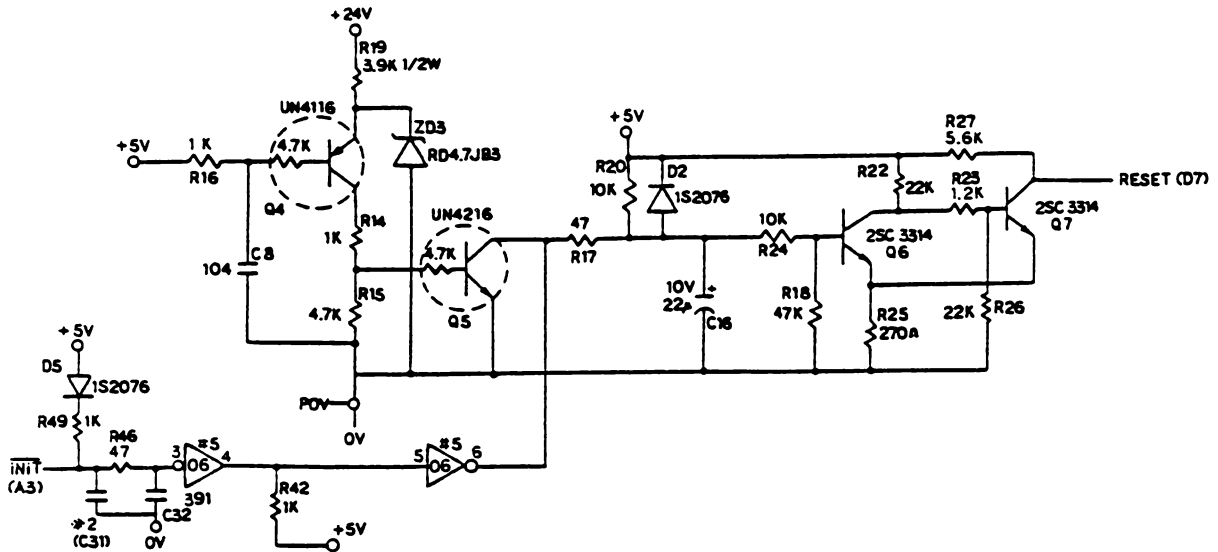

- (1) Changing period by R20 and C16 at POWER ON.
 - (2) Period of +5V power voltage < 4.0V at POWER OFF.
 - (3) Period when INIT signal from interface is 'LOW'.
- In the above 3 periods, RESET signal stays 'LOW' and the CPU is initialized. RESET signal width at POWER ON is about 60ms. Transistors Q6 and Q7 form Schmitt property.

12. Power Supply Circuit

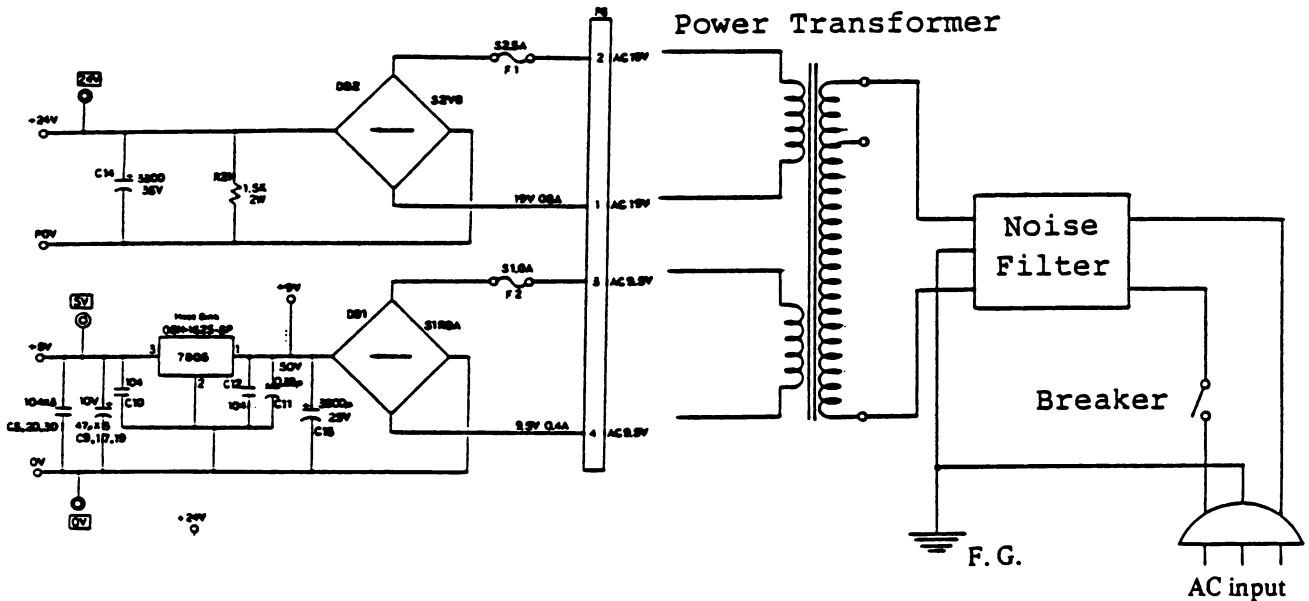

+24V power source is un-regulated. Voltage at rated input without load is 27 (V) and that at self-printing is 24 (V) approximately.

5V power source is stabilized by the 3-terminal regulator 7805. Its output is 5+5% (V) at normal condition. +9V power is taken at the regulator input. It has 10 (V) at rated input.

The POWER switch has the breaker function. It indicates ON though the breaker is operating. The AC input is turned off at this time. If the breaker has tripped, turn off the switch and then turn it on again to reset. The power transformer is equipped with a tap. Wires not used shall be pushed into the pocket of the transformer.

CHAPTER 4
MAINTENANCE

I. Notes for the maintenance

The following notes shall be observed during the maintenance operation to prevent disorder which may be caused by improper handling and operation.

1. Maintenance operation shall be done by the personnel qualified through a regular High-speed Printer Technical Service Course or who has an equivalent technical qualification.
2. Do not perform printing without loading paper.
3. Do not put things on the printer cover during maintenance and operation.
4. Always turn off the power when replacing the parts and units. Especially, when replacing the power supply parts, remove the power cable from the outlet and surely turn off the power.
5. Do not lose screws and washers removed for parts replacement.
6. When using the tools which generate heat such as soldering iron, use care not to damage the resin parts such as cords and printer cover.
7. When replacing the printed circuit boards, the static electricity may ruin the electronic parts on the board. To avoid this, operators are required to touch the metal part of the machine body by hand to discharge the static electricity before handling the boards.
8. Printed circuit boards shall be wrapped in a conductive sheet made of aluminum film when they are carried.
9. After repair, check the repaired and the connectors for correct fit and then conduct operational.

II. Disassembly, replacement and adjustment of parts

1. Detachment & attachment of the cover and ribbon cassette.

[(Detachment)]

- (1) Lift up part (A). (2 positions right & left) of the TOP COVER and disengage the lock. Detach it by pulling it forward.

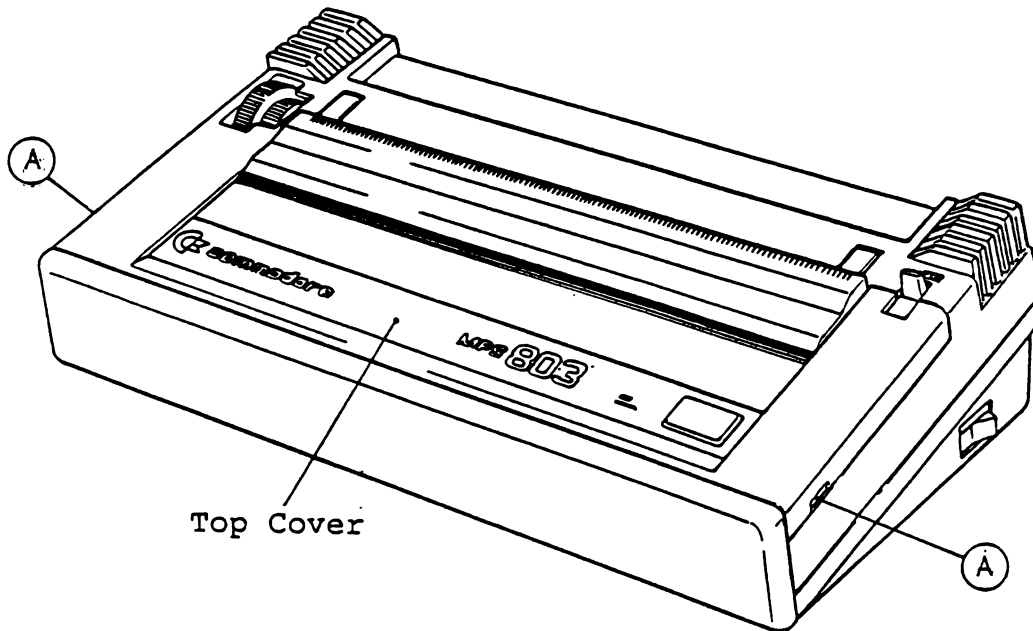

- (2) Return the HEAD to the HOME POSITION (left end).

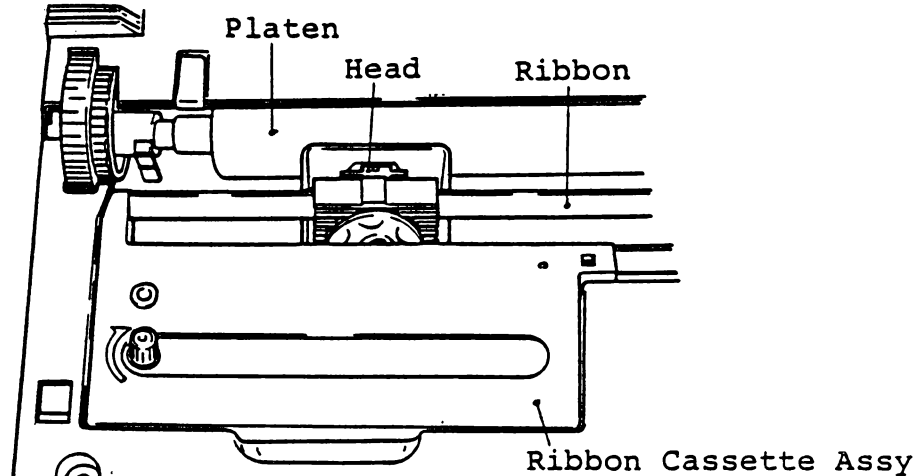

- (3) Pull up the RIBBON GUIDE, along with the ribbon, using the right hand.

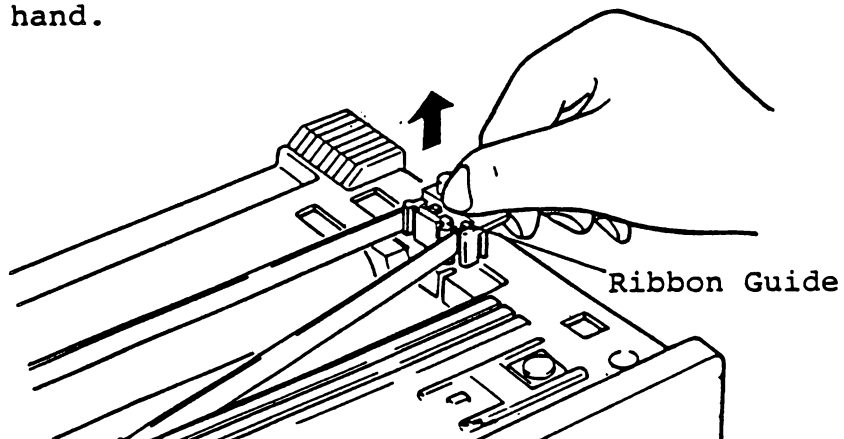

- (4) Turn the RIBBON ADVANCE KNOB in the direction of arrow until the RIBBON GUIDE stops. Wind up the ribbon completely into the cassette.

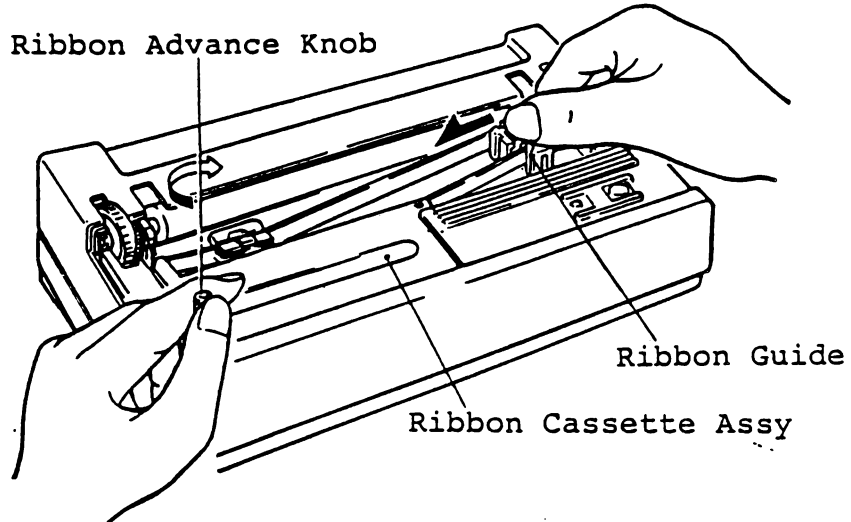

- (5) Hold the cassette at the center and lift it up to detach from the body.

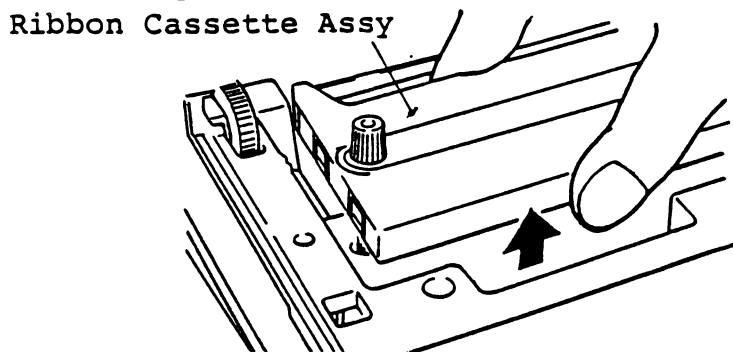

- (6) Remove two BODY COVER SCREWS (+ pan set screw 3 x 12 DB).

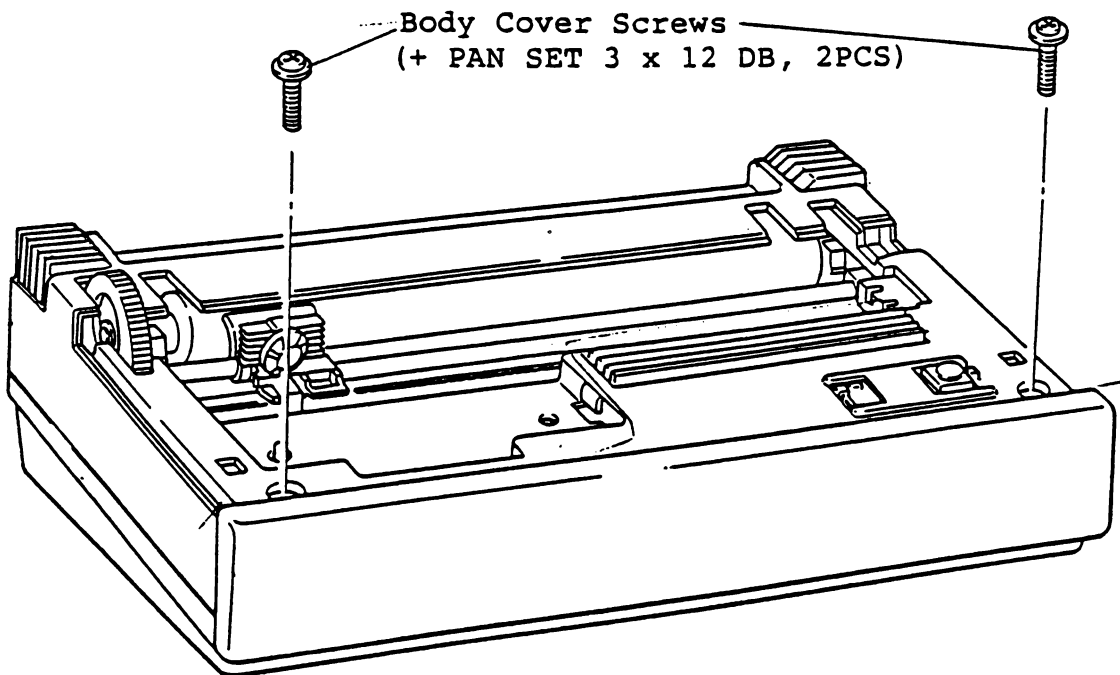

(7) Lift up the BODY COVER on the front a little, pull out the SWITCH CARD HARNESS CONNECTOR and remove the lead wire from the WIRE HOOK B on the BASE COVER. Then the BODY COVER can be detached from the printer body.

Note) Hold the connector when pulling it off. Do not pull the lead wire.

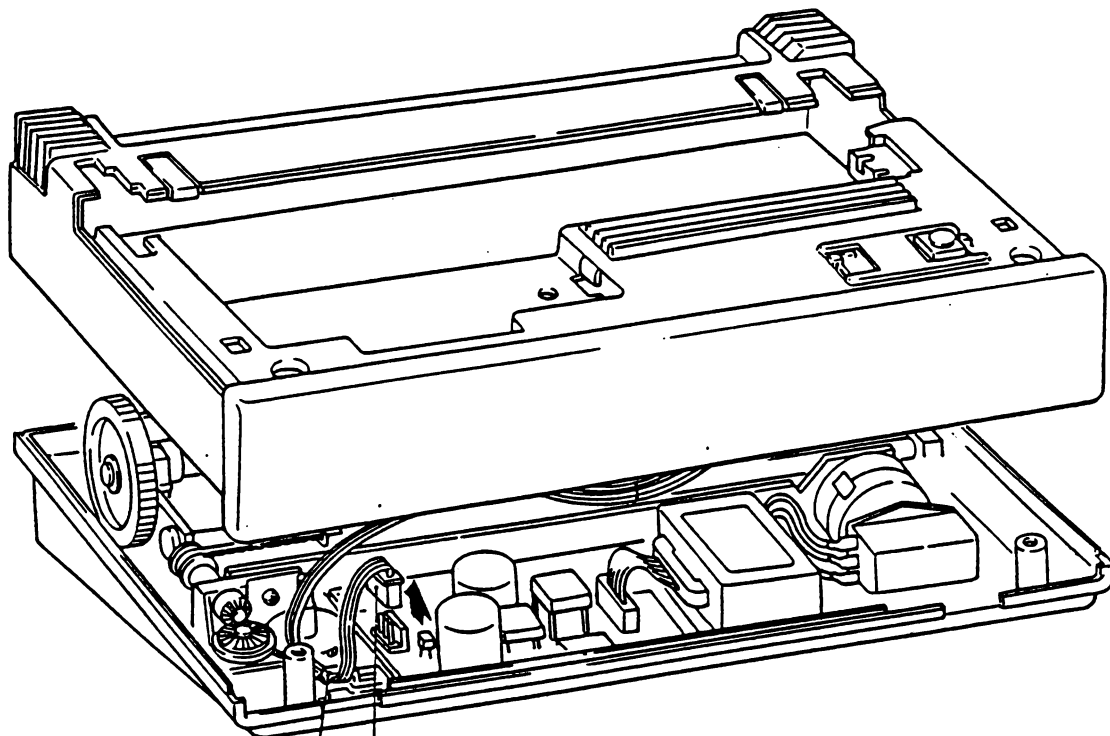

Wire Hook B

Switch Card Harness Connector

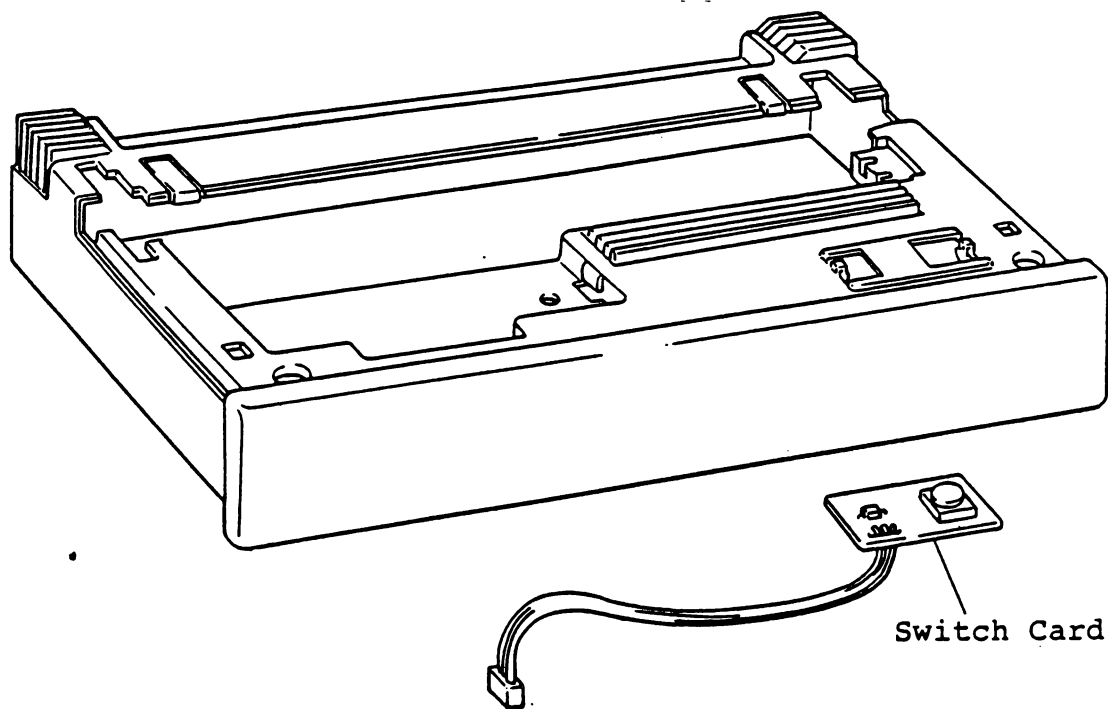

Switch Card

[Attachment]

- (1) Attach the cover following the reverse procedures of detachment.
- (2) For attaching the ribbon cassette, refer to Section 4 of CHAPTER 2.

2. Detachment & attachment of the head

[Detachment]

- (1) Detach the top cover.
- (2) Move the head to the right end as shown below.

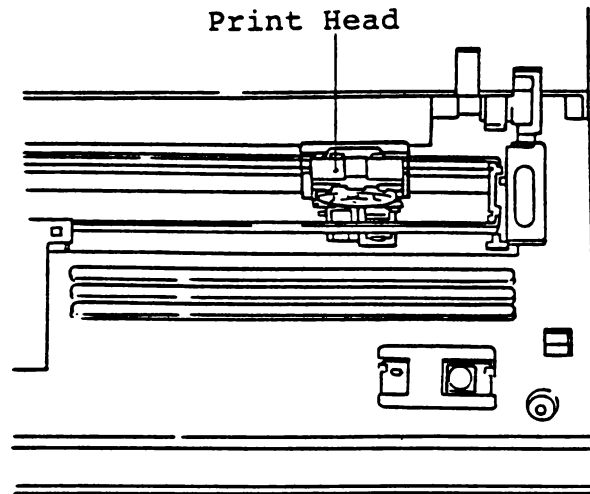

- (3) Pull out the bent tab using a ball-point pen.

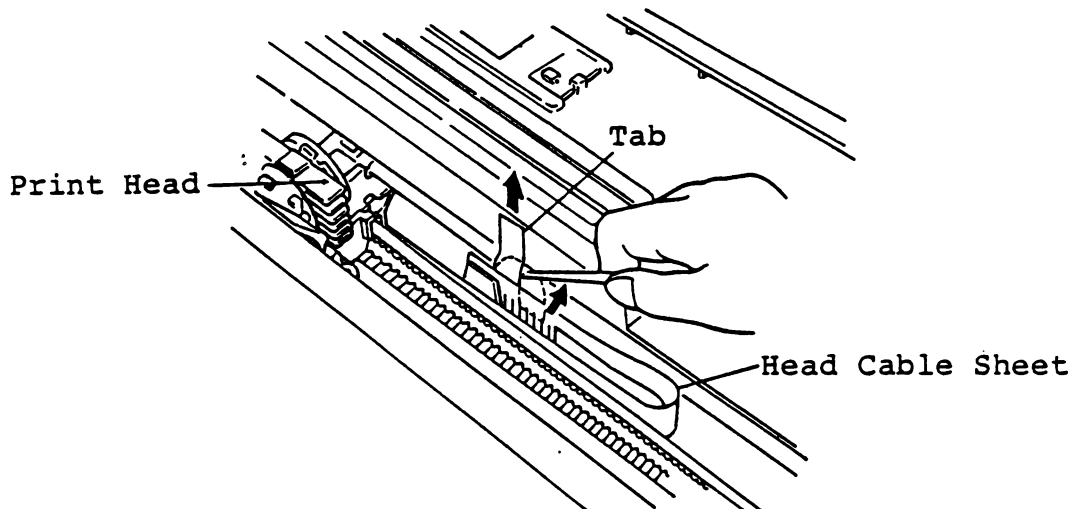

- (4) Hold the tab with hand and pull the cable upward.

- (5) Slide the HOLDING PLATE fixed on the carriage to the right and pull it upward.

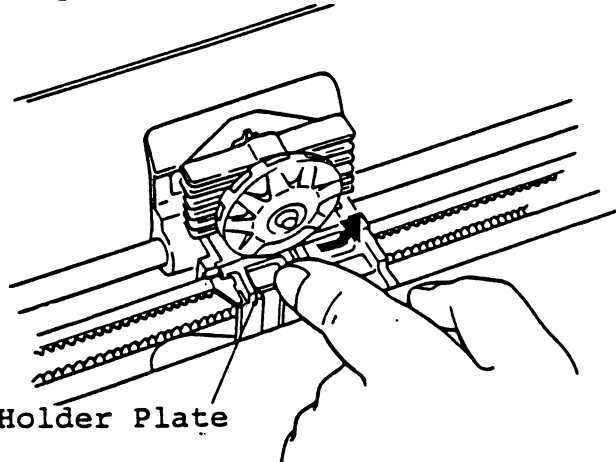

- (6) Push the HEAD HOLDING SPRING onto the PLATEN and pull upward the PRINT HEAD strongly to remove the HEAD.

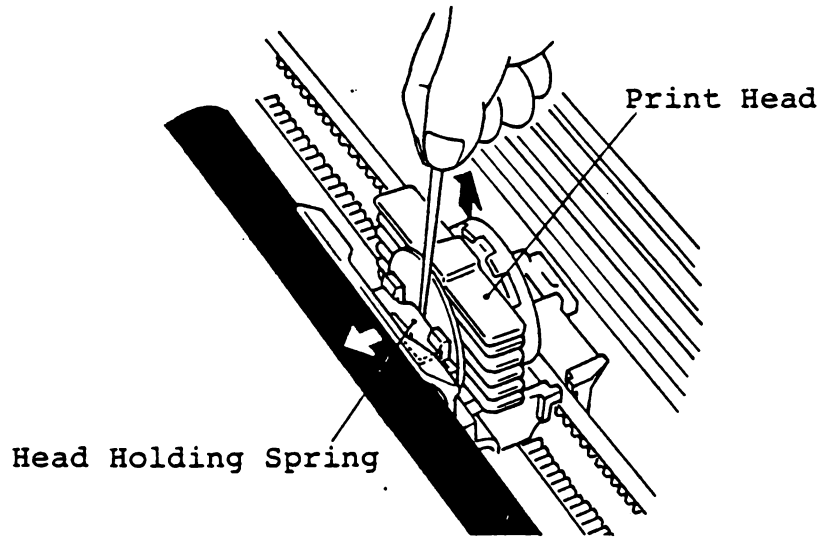

(Attachment)

- (1) Insert the PRINT HEAD lightly into the CARRIAGE.

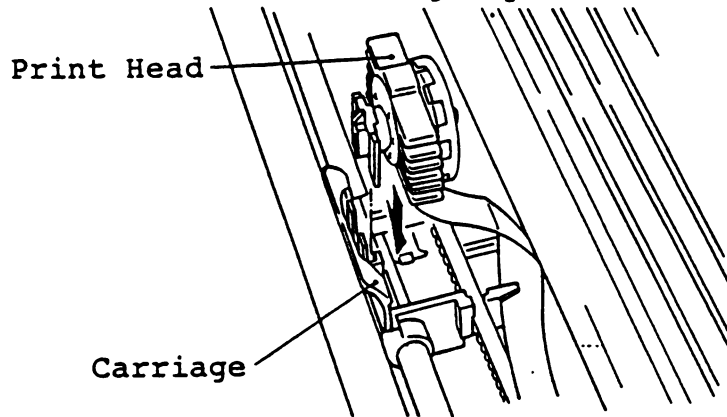

- (2) Install the CABLE into the CARRIAGE and CABLE BRACKET as shown.

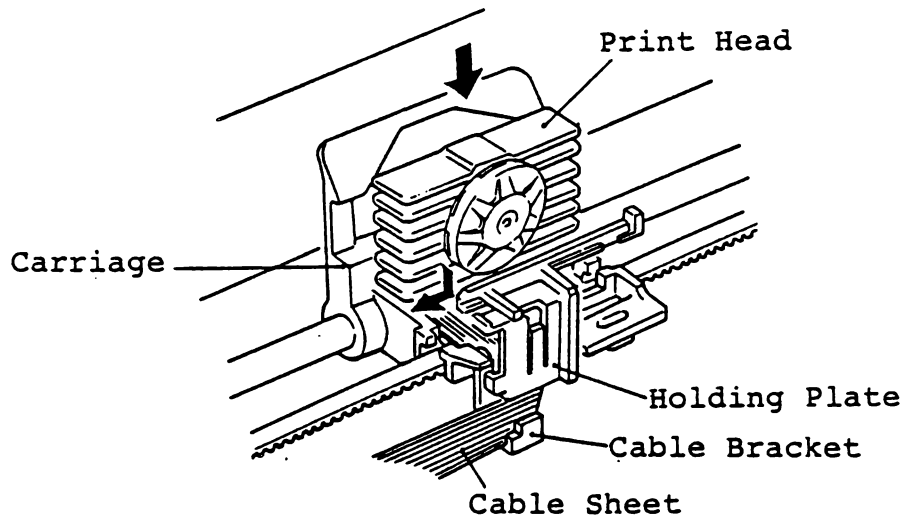

- (3) Install the HOLDING PLATE and slide it to the left.
 (4) Push down the HEAD strongly to fix it into place.
 (5) Bend the TAB and insert it to the connector.
 (6) Make sure the cable is installed in the FRAME GUIDE.

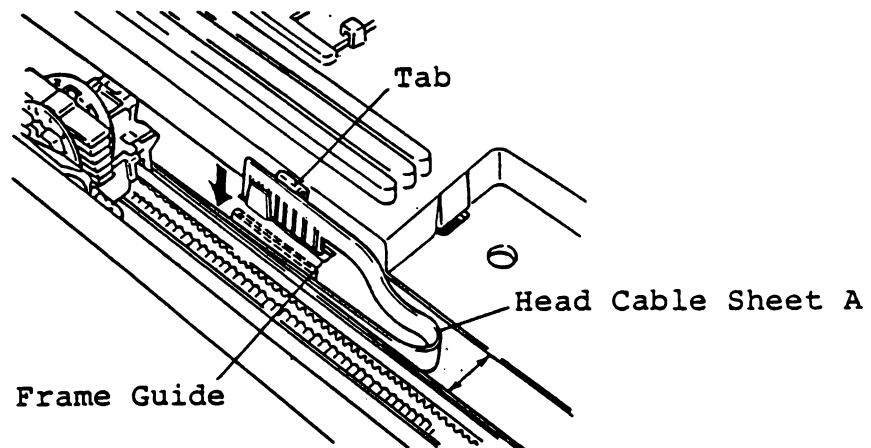

- (7) Check if the carriage moves smoothly right and left by hand. Then turn on the power and perform SELF-TEST to check if printing is correctly done.
 (Turn on the power while pressing the PAPER ADVANCE switch.)

(Adjustment of the head to platen clearance)

If the clearance is not properly provided, such troubles as uneven darkness of print characters and ribbon blotting may occur. To avoid this, adjust the clearance properly.

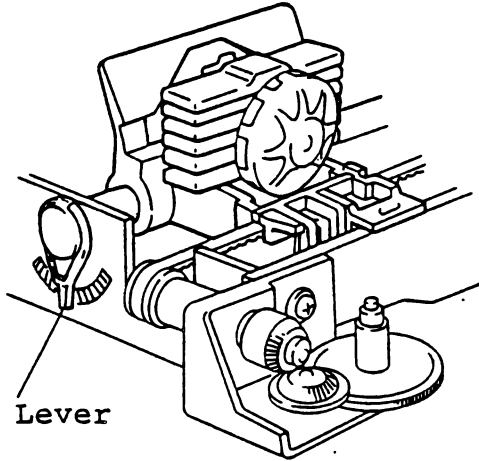

Clearance Adjusting Lever

- (1) Use the CLEARANCE ADJUSTING LEVERS provided to the FRAME on both sides to adjust the clearance to 0.4 - 0.45mm. Perform adjustment on the both sides of the PLATEN.

3. Detachment & attachment of the frame unit

[Detachment]

- (1) Detach the cover as described before.
 - (2) Remove two FRAME TIGHTENING SCREWS (+ pan set 3 x 8 DB).
 - (3) Pull off the PE/EP HARNESS ASSY and connectors of the CR motor and LF motor.
- Then the FRAME UNIT can be separated from the BOTTOM COVER.

Note) Pull off the connectors by holding the connector body. Do not hold the lead wires.

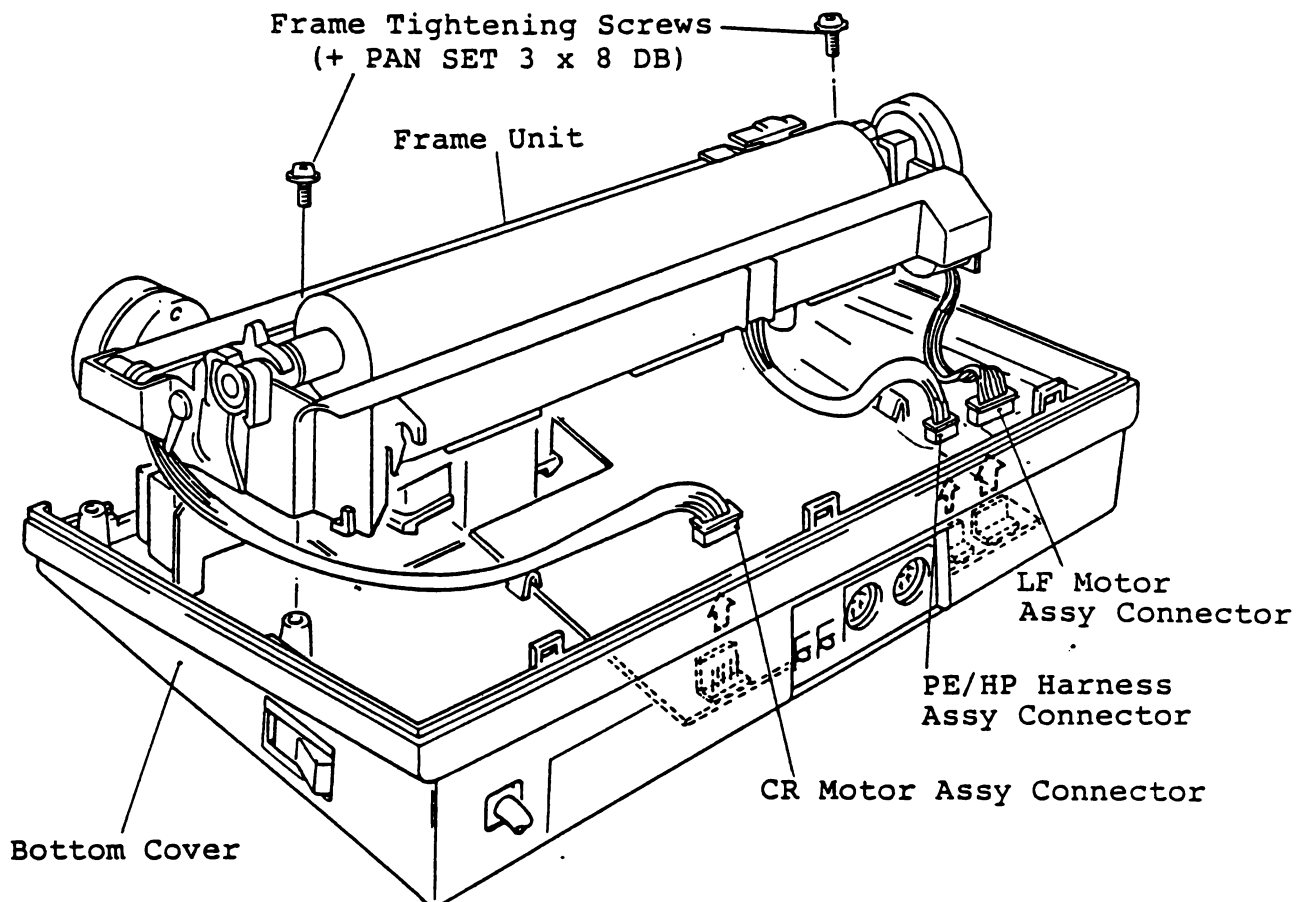

[Attachment]

- (1) Perform attachment by following the reverse of the detachment procedures.

Note) Use care not to catch the lead wires during attachment.

4. Detachment & attachment of the T-belt

[Detachment]

- (1) Detach the FRAME UNIT following the cover and head detachment procedures described before.
- (2) Remove the tightening screw A on the FRAME PLATE. Move the PLATE in the direction of arrow and remove.

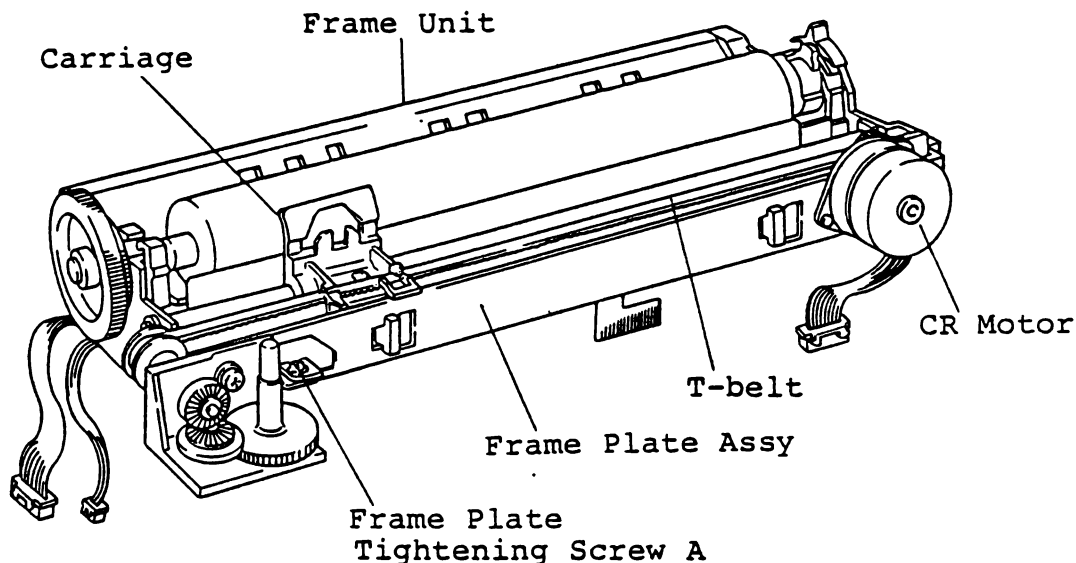

- (3) Turn the PARALLELISM ADJUSTING CAM once, located on the right side of the FRAME. Pull it out where the holes coincide, together with the guide bar.

- (4) Remove the carriage and T-belt. Attach a new T-belt.

[Attachment]

- (1) Perform attachment following the reverse of the detachment procedures.

[T-belt adjustment]

If tension of the T-belt is not proper, the belt may skip on the gears or the load in carriage travel often abnormally increases.

Adjust T-belt tension when the belt and CR motor are replaced.

- (1) Move the carriage to the left end of the FRAME.
- (2) Proper tension is that the T-belt deflects for 8 - 10mm when applied with a vertical load of 100g at the center of span using a tension gauge. Adjust by loosening the tightening screw of the CR motor and rotate the CR motor until proper tension is found. Tighten the mounting screws of the CR motor.

5. Replacement of the CR motor

[Detachment]

- (1) Detach the frame unit following the procedures for detaching the cover and head described before.
- (2) Remove two CR MOTOR MOUNTING SCREWS (A) and detach the motor assy from the FRAME PLATE.

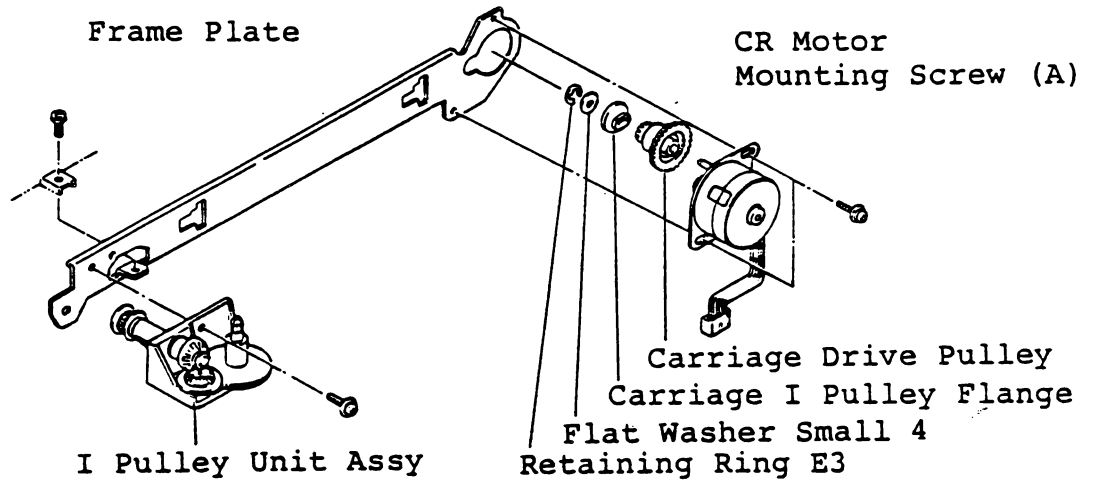

- (3) Remove RETAINING RING E3 (B) from the CR MOTOR UNIT.
- (4) Remove FLAT WASHER SMALL 4 (C), CARRIAGE I PULLEY FLANGE (D) and C DRIVE PULLEY (E) from the shaft.
- (5) Attach the parts removed in 4 above to a new CR motor and secure them with RETAINING RING E3 (B).

[Attachment]

- (1) Perform attachment following the reverse if the detachment procedures.

[Adjustment required by replacement of the CR motor]

- (1) Adjust the tension of the T-belt.
Refer to the adjustment procedures described before.

6. Detachment & attachment of the I pulley unit assy

[Detachment]

- (1) Detach the assy following the detachment procedures for the cover, and remove a + PAN SEMS 3 x 8 DB (A) on the frame front.

(Attachment)

- (1) Attach a new I PULLEY UNIT following reversely the detachment procedures.

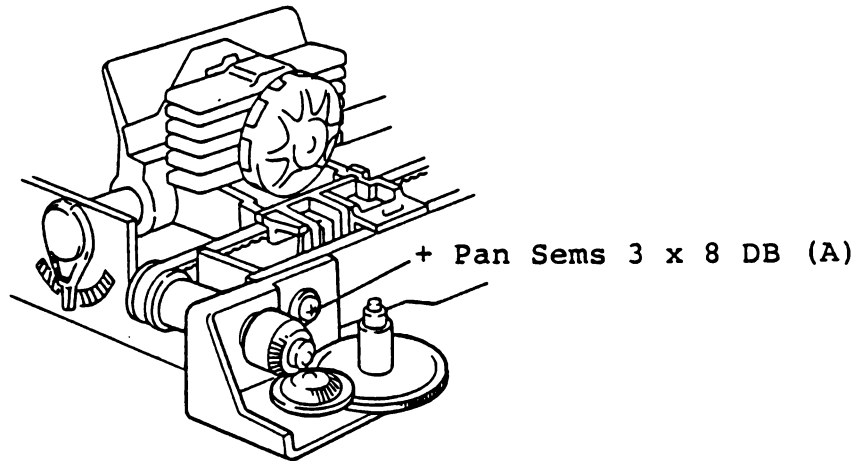

7. Detachment & attachment for the LF motor

(Detachment)

- (1) Detach the FRAME UNIT following the reverse of the detachment procedures for the cover and head described before.
- (2) Detach the PLATEN ASSY, PLATEN SHAFT BRACKET and RELEASE LEVER upward.
Pull outward and disengage the latches of the platen shaft bracket to detach the bracket.

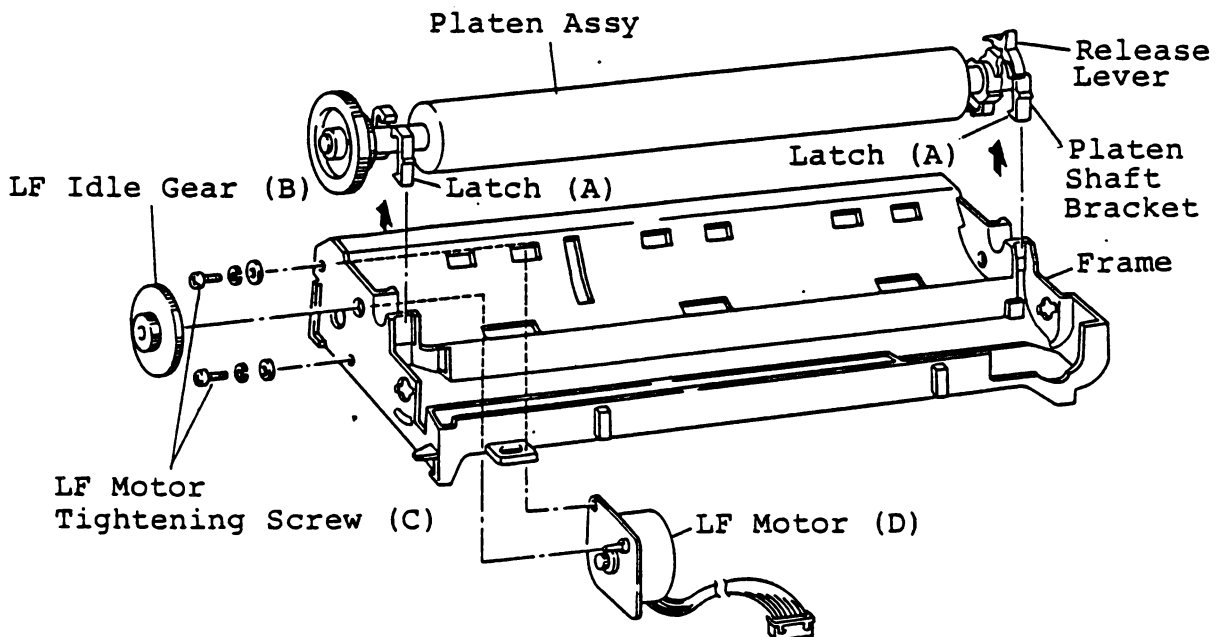

- (3) After detaching LF IDLE GEAR (B), remove LF MOTOR TIGHTENING SCREW (C) and detach LF MOTOR (D) from the frame.

1. [Attachment]

(1) Mount a new LF motor to the frame. Then, attach the LF idle gear, platen assy, release lever and platen shaft bracket to the frame.

Note) a. Attach the platen assy, release lever and platen shaft bracket so that the release lever engages with P release gear on the CLOSE side. See the illustrations below.

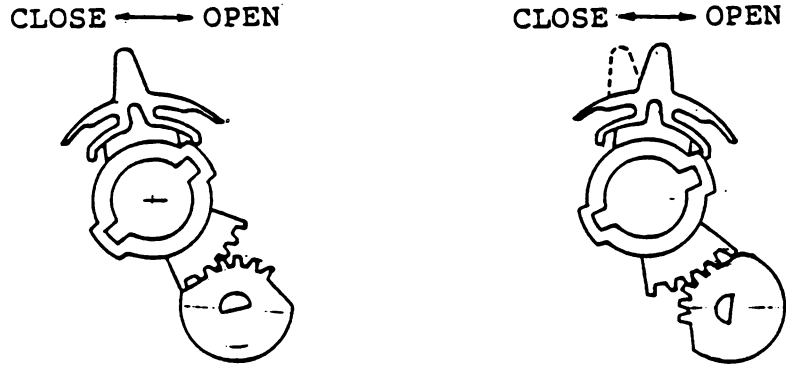

b. Make sure the latches (A) of the platen shaft bracket (2 each) surely engage with the frame.

2. [Adjustment of LF motor mounting position]

(1) Loosen the LF Motor tightening screw and adjust so that the backlash between LF motor gear and LF idle gear is maintained within 0.05 to 0.2mm.

8. Detachment and attachment of PE/HP harness assy

1. [Detachment]

- (1) Detach the frame unit following the detachment procedures for the cover and head as described before.
- (2) Turn the frame unit upside down and detach the PE SWITCH HOLDER by opening the LATCHES (A) into the direction of arrow.
- (3) Remove the HP SWITCH MOUNTING SCREW (B) and detach the HP SWITCH upward.

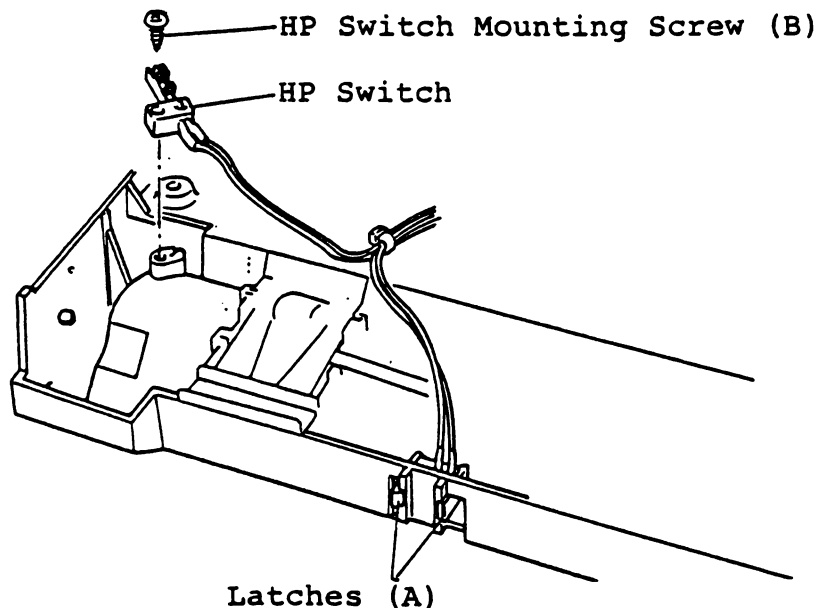

- (4) Detach the PE switch assy by opening the latches engaged with the PE switch holder.
 - (5) Attach a new PE switch assy to the PE switch holder.
- Note) Make sure the latches securely engage with the PE switch assy.

(Attachment)

- (1) Attach PE switch holder and HP switch following reversely the detachment procedures.

9. Detachment & attachment of the logic card

(Detachment)

- (1) Detach the logic card following the detachment procedures of the cover and frame unit as described before.
 - (2) Pull out the CONNECTOR (A) of the TRANSFORMER ASSY.
- Note) Hold the connector to pull it out. Do not hold the lead wires.
- (3) Pull out the INT FG WIRE (B).
 - (4) Lift up the LOGIC CARD and open the holding parts (C), (D) and (E) into the direction of arrow.
- Disengage and pull the card forward to remove it.

(Attachment)

- (1) Attach the card following the reverse of the detachment procedures.

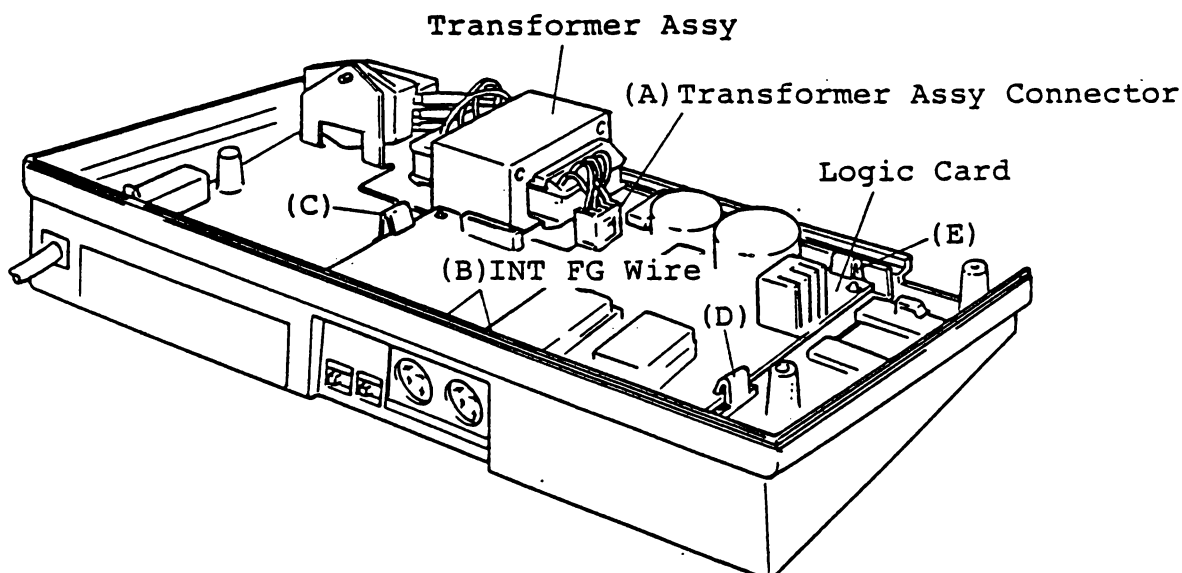

10. Detachment & attachment of the transformer

[Detachment]

- (1) Detach the transformer by following the detachment procedures for the cover and frame unit first.
- (2) Disconnect two Faston terminals connected to the noise filter.
- (3) Remove two TRANSFORMER MOUNTING SCREWS (A) and slide the transformer backward to detach it.

[Attachment]

- (1) Attach the TRANSFORMER by inserting it into the hole of the POWER SUPPLY HOLDER and tighten with two screws.
- (2) Connect two Faston terminals to the noise filter.

11. Detachment & attachment of the noise filter

[Detachment]

- (1) Detach the noise filter by following the detachment procedures of the cover and frame unit.
- (2) Disconnect the Faston terminals (3 left, 2 right) connected to the noise filter.
- (3) Remove a mounting screw (B) on top, slide the filter upward to detach.

12. Detachment & attachment of the power switch

[Detachment]

- (1) Detach the cover and frame unit as described before.
- (2) Pull the POWER SWITCH upward by opening the latches.

[Attachment]

- (1) Attach the switch following the reverse of the detachment procedure. After attachment, put the POWER CORD between the rib and switch. (to eliminate looseness of the switch attachment)

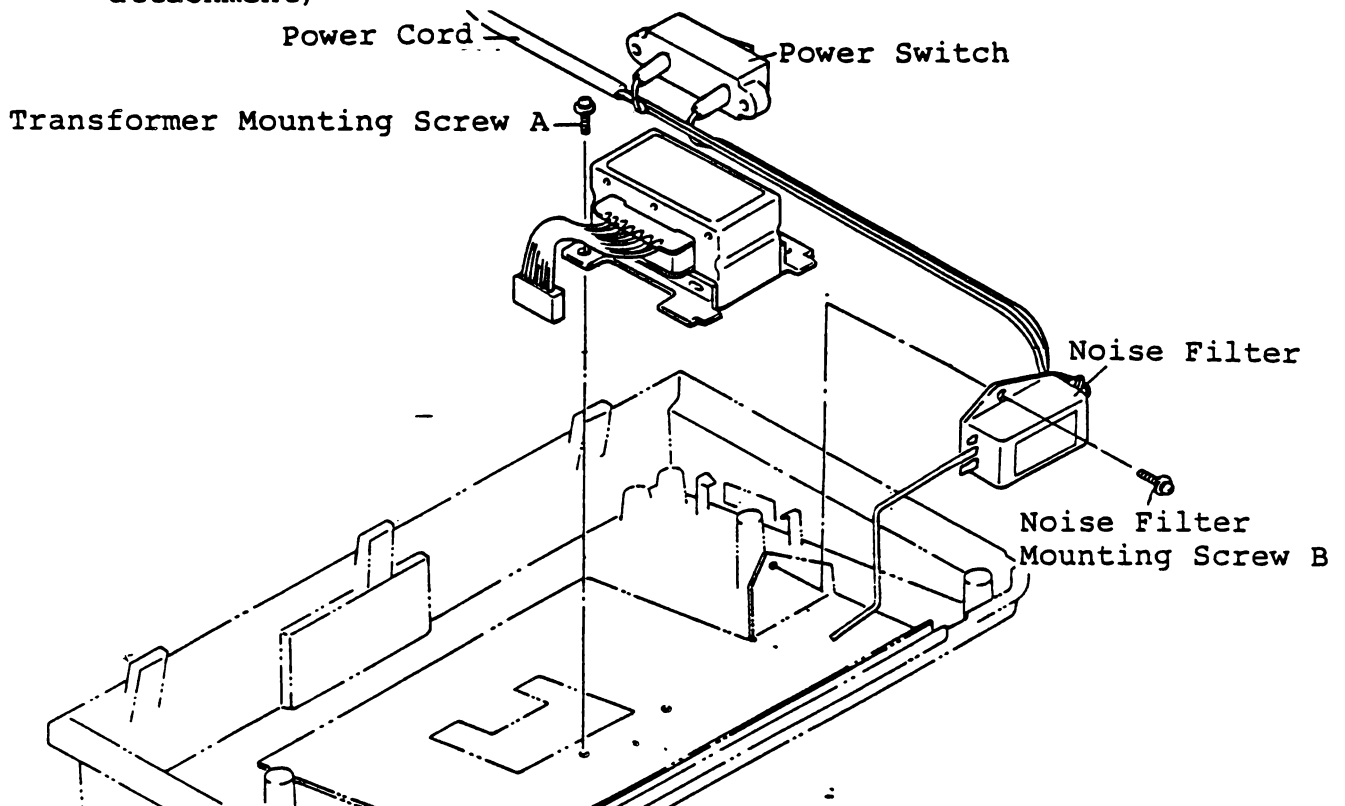

13. Detachment & attachment of the power cord

[Detachment]

- (1) Detach the cover and frame unit as described before.
- (2) Disconnect two Faston terminals on top from the noise filter, and remove the tightening screw of the GROUND terminal.

Remove two CORD RETAINING SCREWS and pull out the cord through the hole on the back of the BOTTOM COVER.

[Attachment]

- (1) Attach the cord following the reverse of the detachment procedure.

III. Lubrication

Supply oil to the parts mentioned below at replacement.

- (1) GUIDE BAR all around
- (2) Sliding part between FRAME PLATE and CARRIAGE
- (3) Shaft with which LF IDLE GEAR engages
- (4) Engagement between PLATEN SHAFT BRACKET and PLATEN SHAFT
- (5) PE ROLLER SHAFT GUIDE of the FRAME and contacting part between PF ROLLER SHAFT and ROLLER RETAINING SPRING.

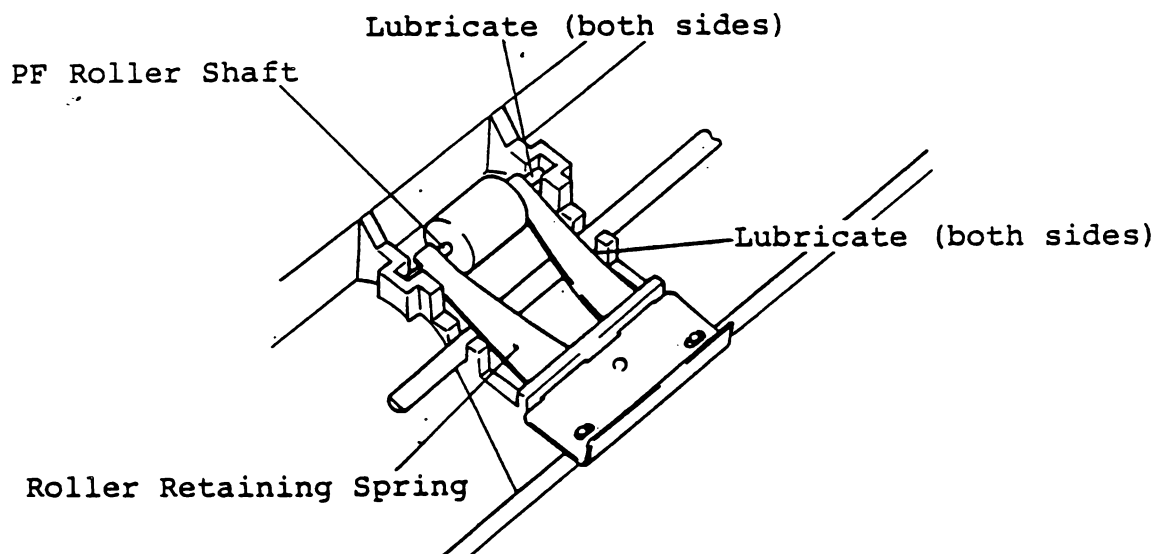

(1) - (4) Silicon oil KF961 (100cs)
(Shinetsu Silicon)

(5) Grease B

Note) Apply lubricant thinly and evenly. May drip if excessively applied.

CHAPTER 5
CIRCUIT DIAGRAMS

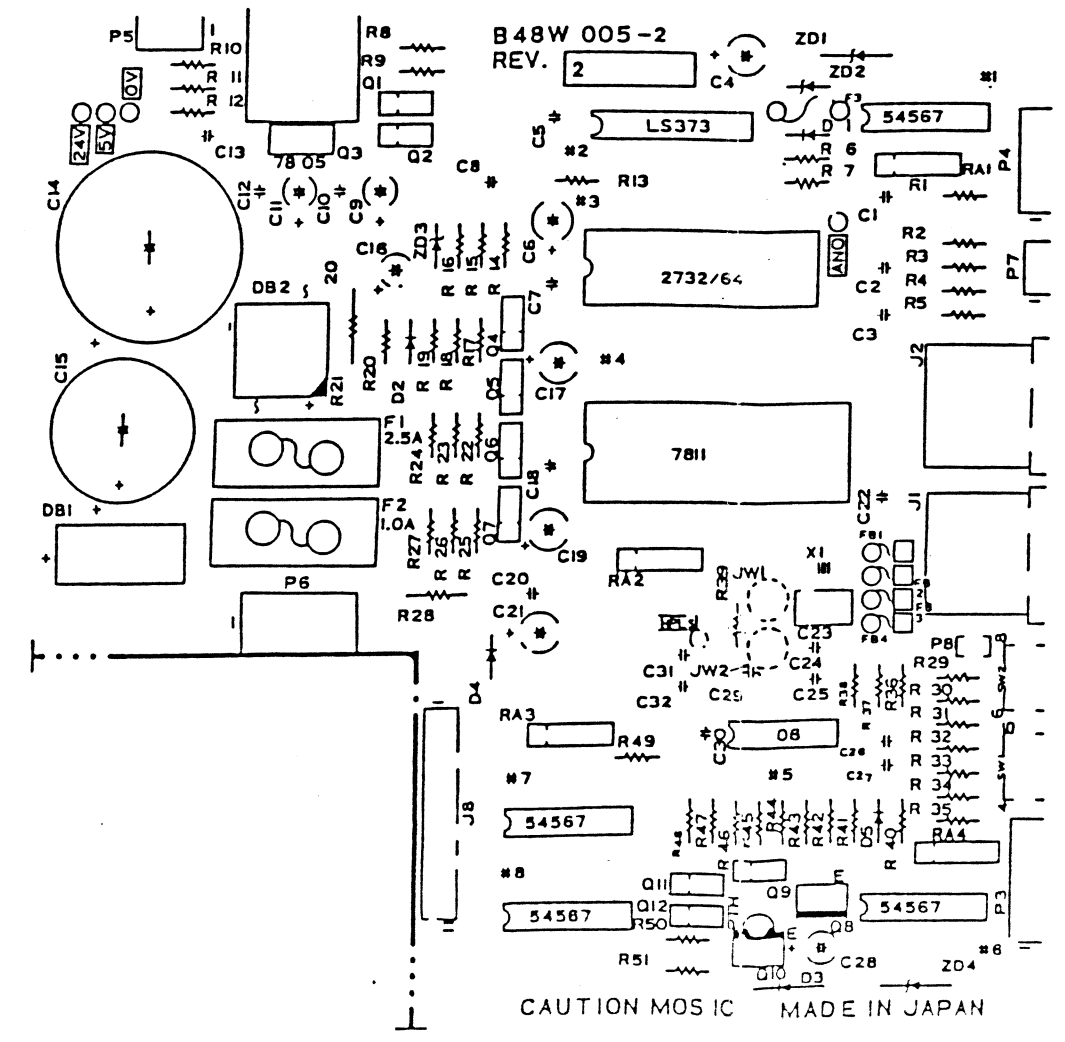
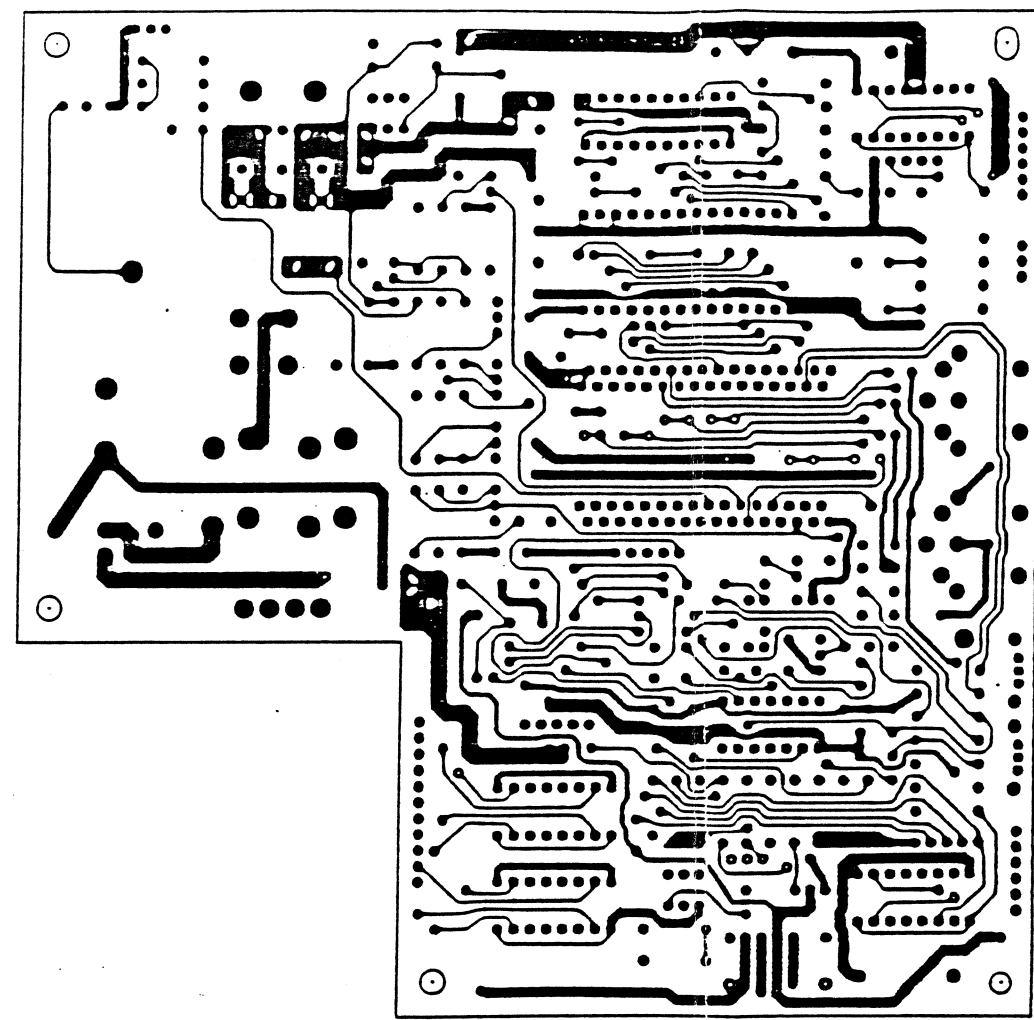
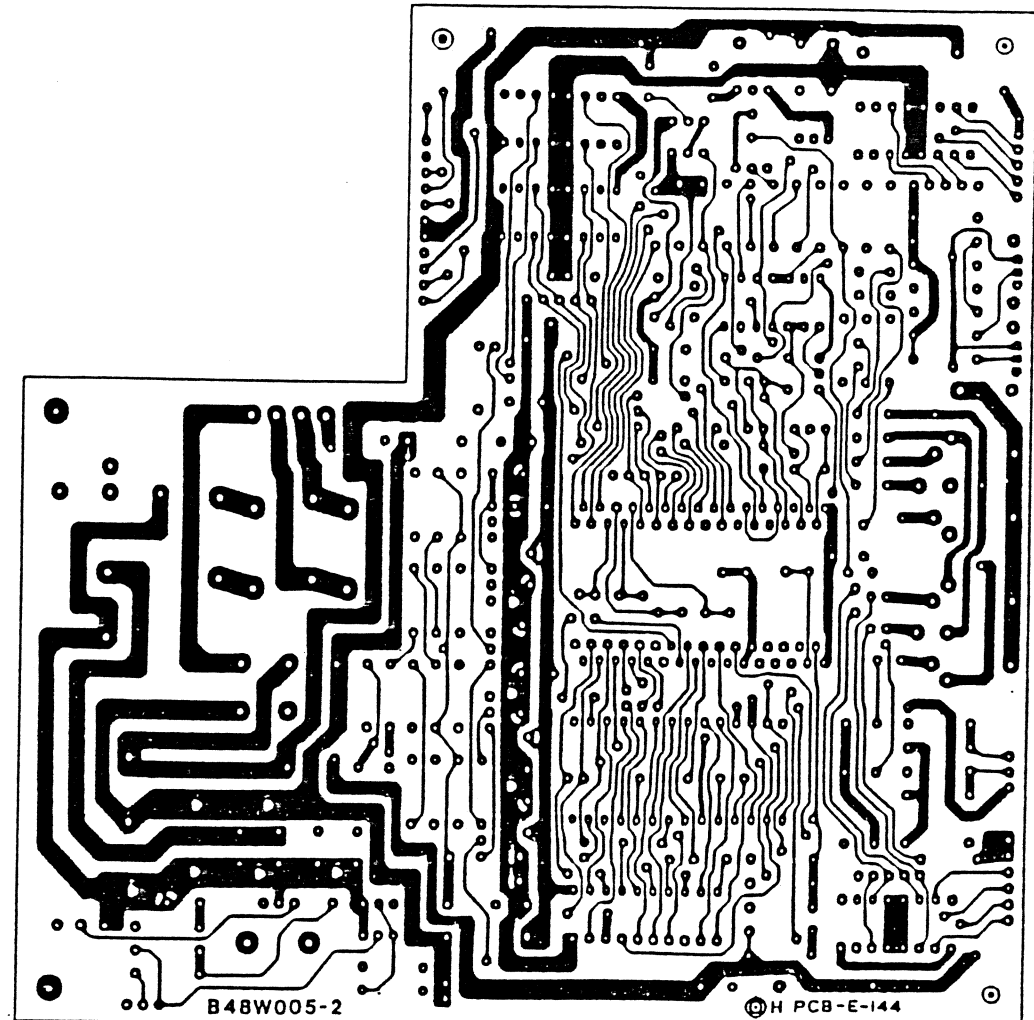

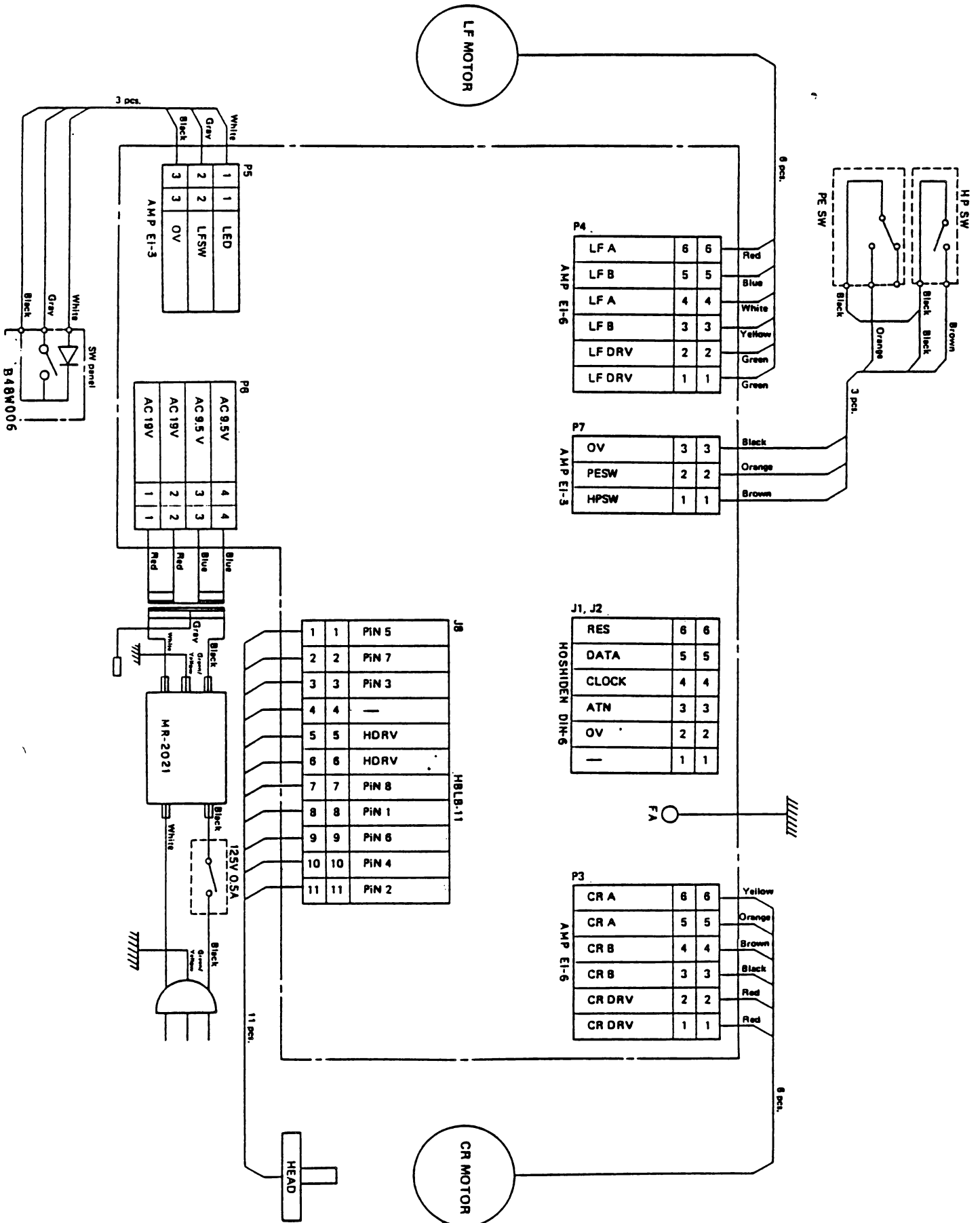

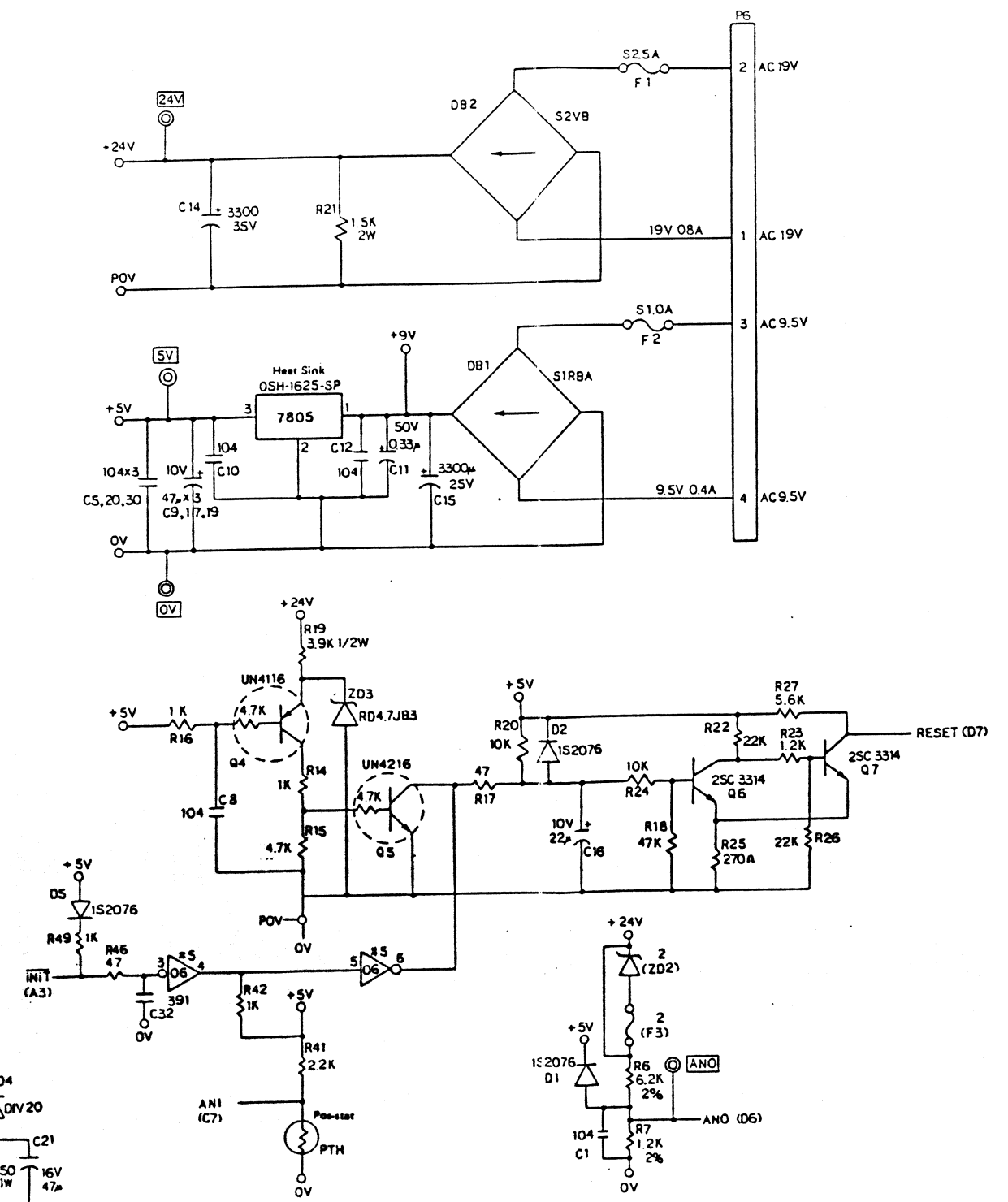
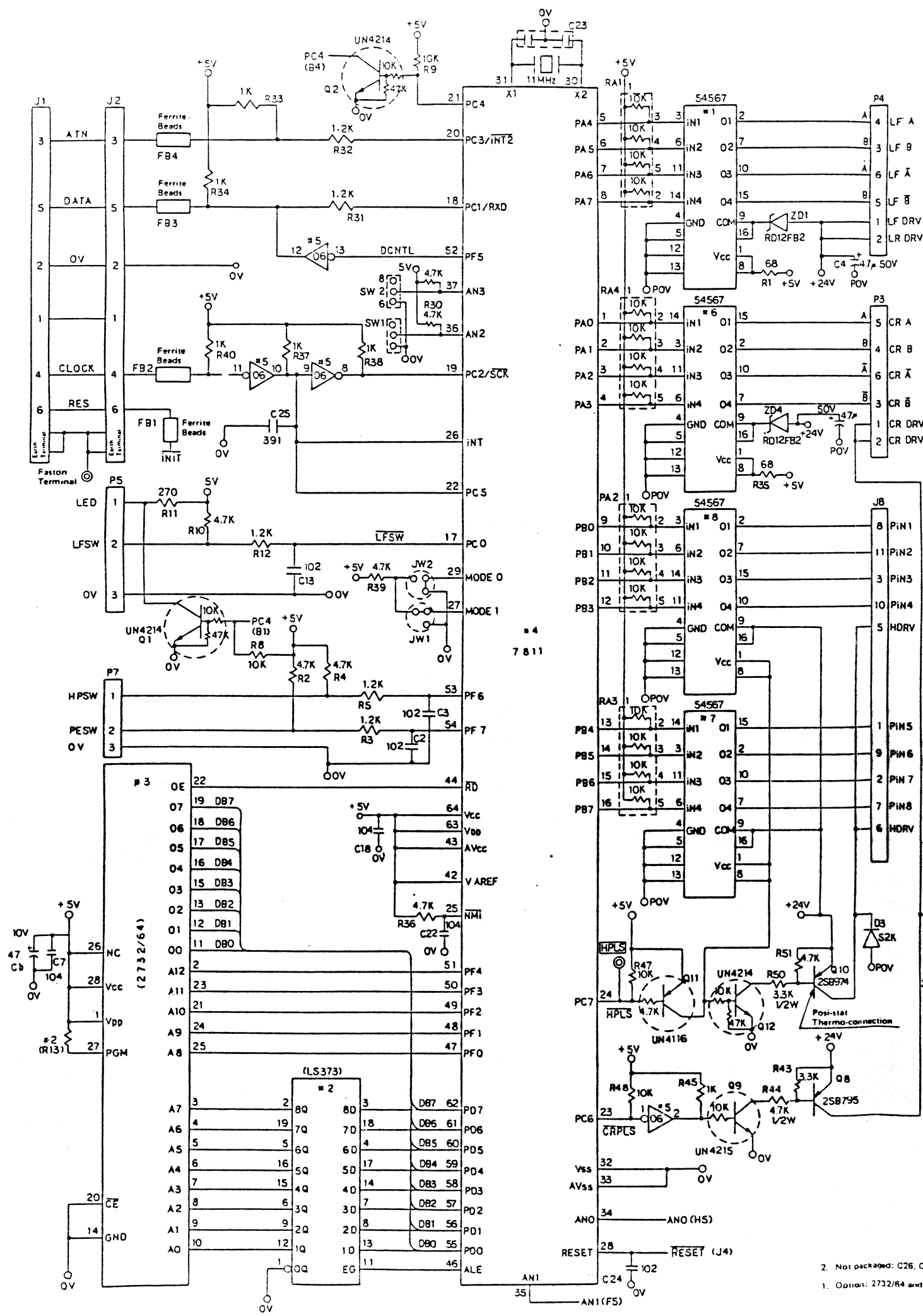

2. Not packaged: C26, C27, C29, C31, ZD2, F3 and R13
 1. Option: 2732/64 and 74LS373

CHAPTER 6
PACKAGE DRAWINGS

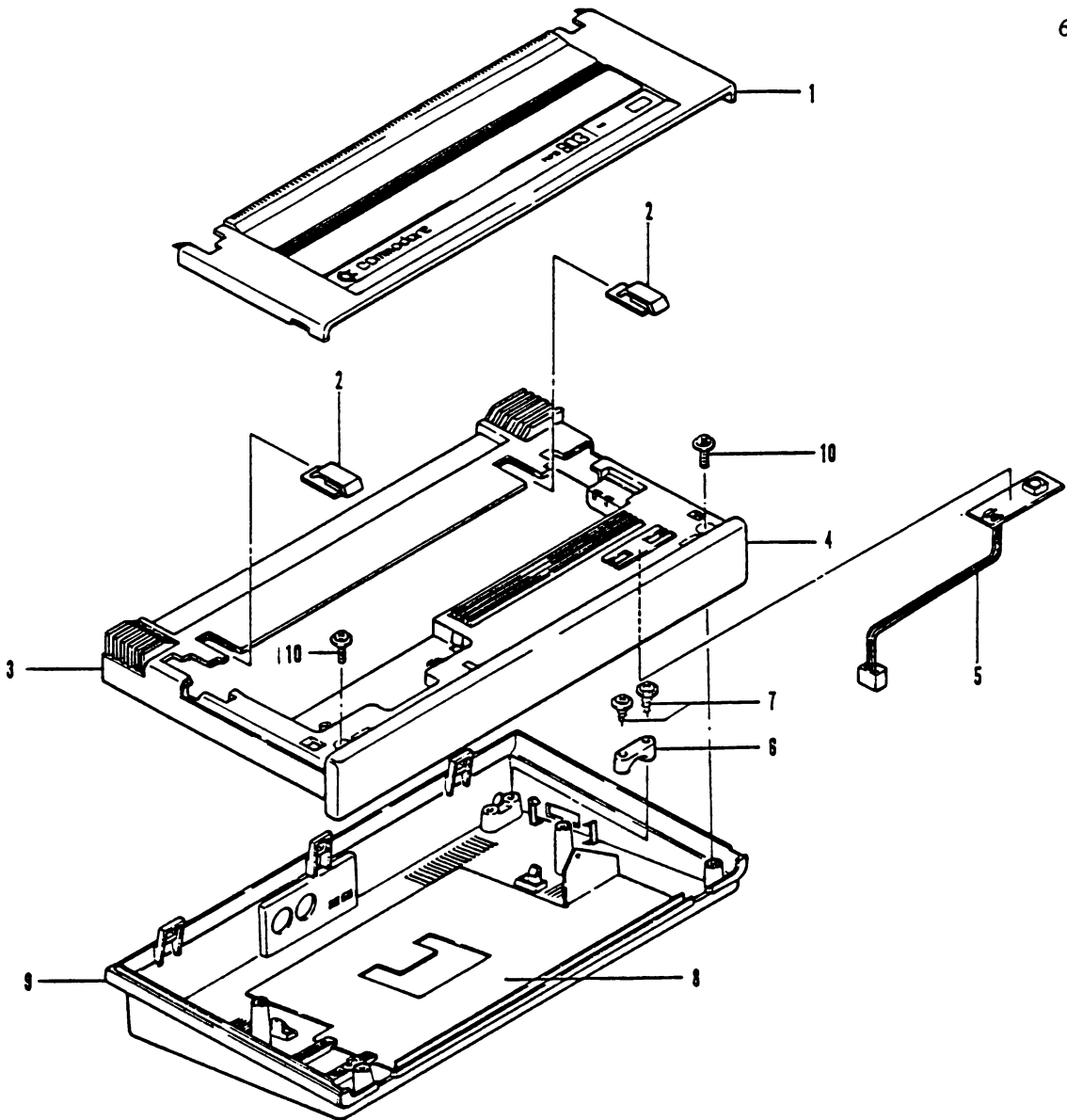

1.	Parts Code	Q'ty	Name
1	U23049001	1	TOP COVER ASSY
2	U23082001	2	COVER LID
3	U23047001	1	BODY COVER
4	U23048001	1	FRONT COVER
5	U32143001	1	CIRCUIT BOARD 48W006 ASSY
6	571969000	1	CORD HOLDER 2
7	U23057001	2	PAN CUP B 3.0 x 20
8	U23056000	1	POWER SUPPLY HOLDER
9	U23044001	1	BOTTOM COVER ASSY
10	533655001	2	+ PAN SET 3 x 12DB

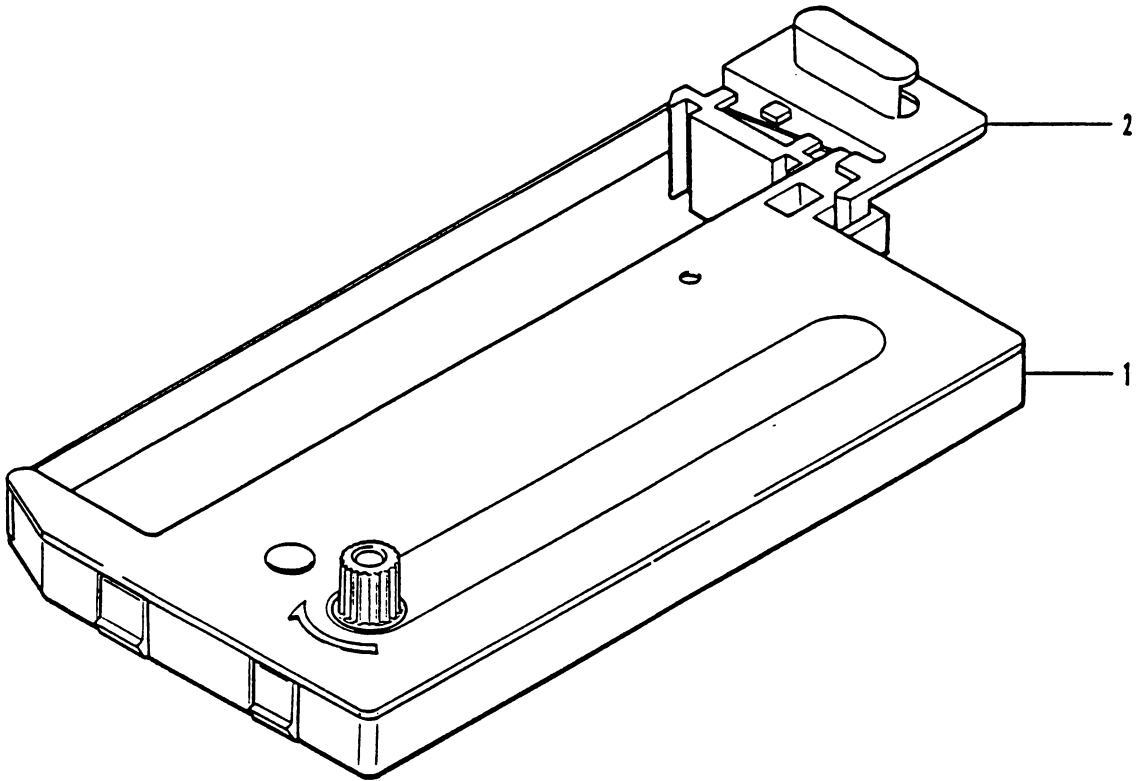

2.	Parts Code	Q'ty	Name
1	U23036001	1	RIBBON CASSETTE ASSY
2	U23042001	1	RIBBON GUIDE

NOTE: Service order

U23095001 RC Box A12 ASSY

U23097001 RC Box A300 ASSY

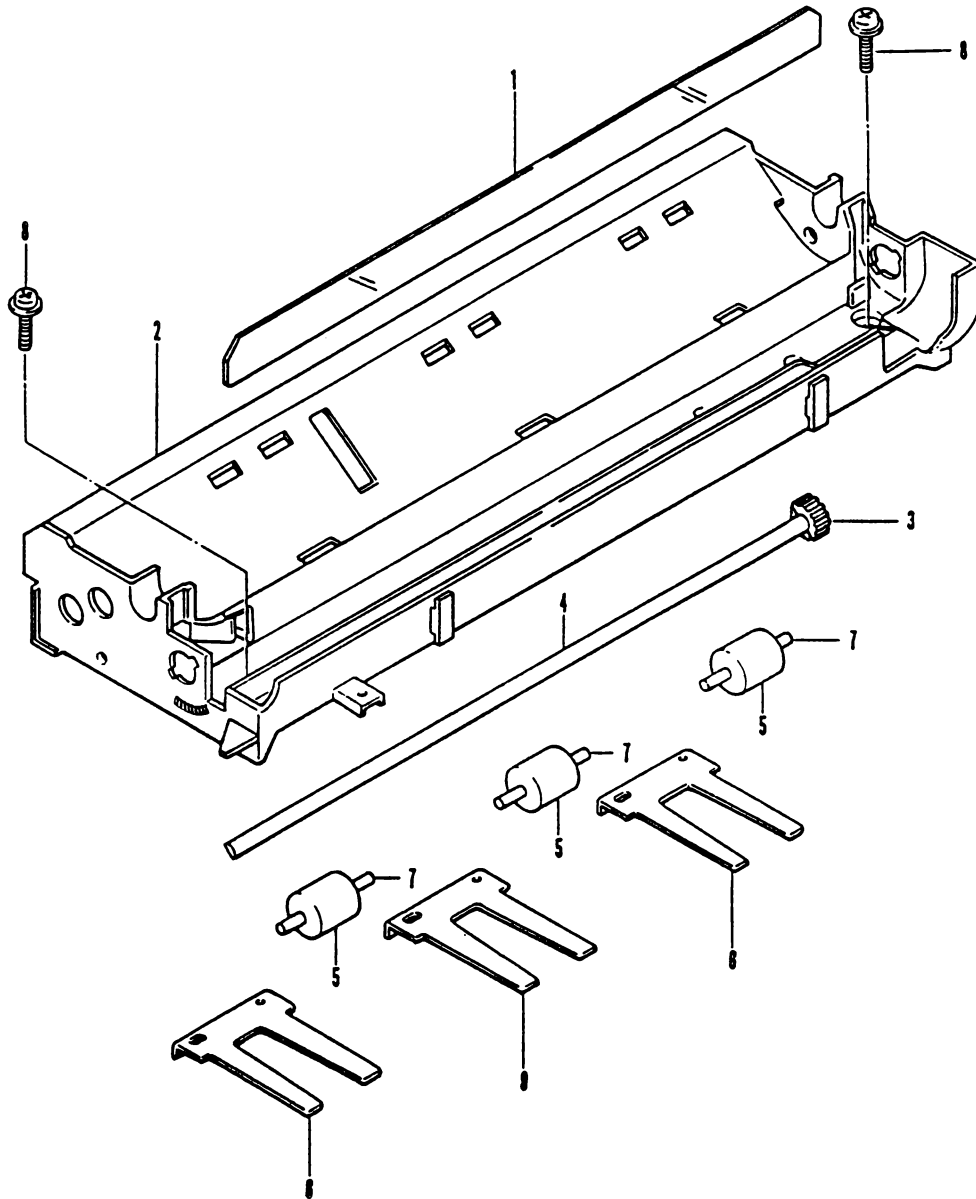

3.	Parts Code	Q'ty	Name
	1	1	P HOLDER FILM
	2	1	FRAME
	3	1	P RELEASE GEAR
	4	1	P RELEASE SHAFT
	5	3	PF ROLLER ASSY
	6	2	ROLLER HOLDING SPRING
	7	3	PF ROLLER SHAFT
	8	2	+ PAN SEMS 3 x 8 DB
	9	1	ROLLER HOLDING SPRING A

NOTE: Parts code of ASSY of 1-7 above,
U23000001 FRAME ASSY

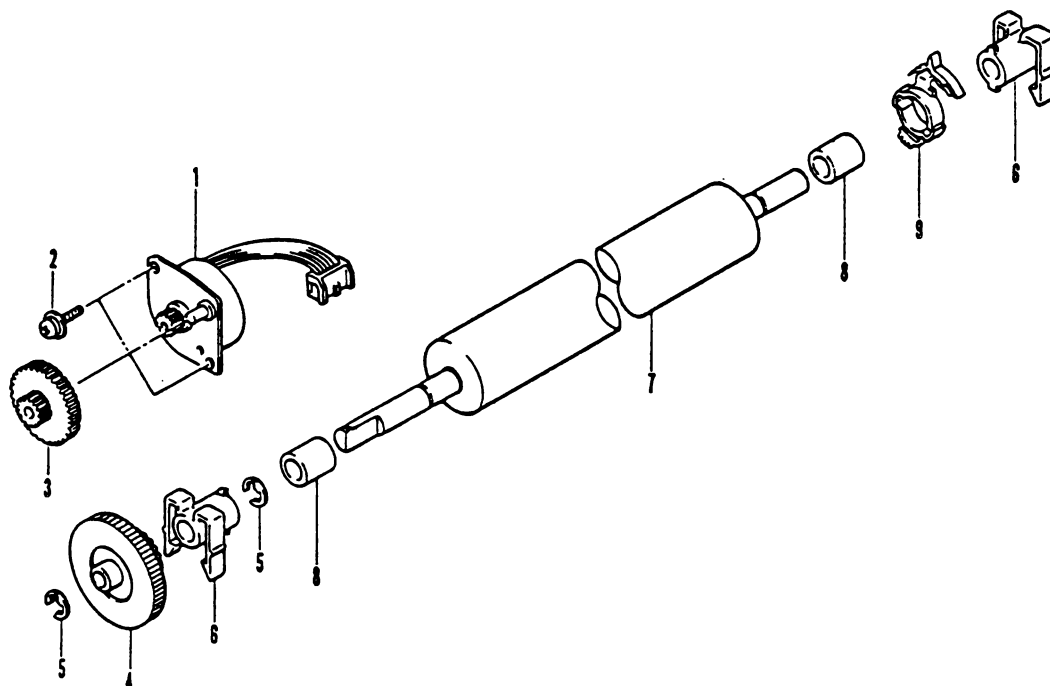

4.	Parts Code	Q'ty	Name
1	Z20276001	1	MOTOR ASSY BP483518
2	U20545001	2	+ PAN SEMS 2.6 x 8DB
3	U23028000	1	LF IDLE GEAR 216
4	U23032001	1	PLATEN KNOB
5	048060345	2	RETAINING RING E6
6	U23154000	2	PLATEN SHAFT BRACKET
7	U23030001	1	PLATEN
8	U23033001	2	PLATEN SHAFT
9	U23034001	1	RELEASE LEVER

NOTE: Parts code of ASSY of 4-9 above,
U23029001 PLATEN ASSY

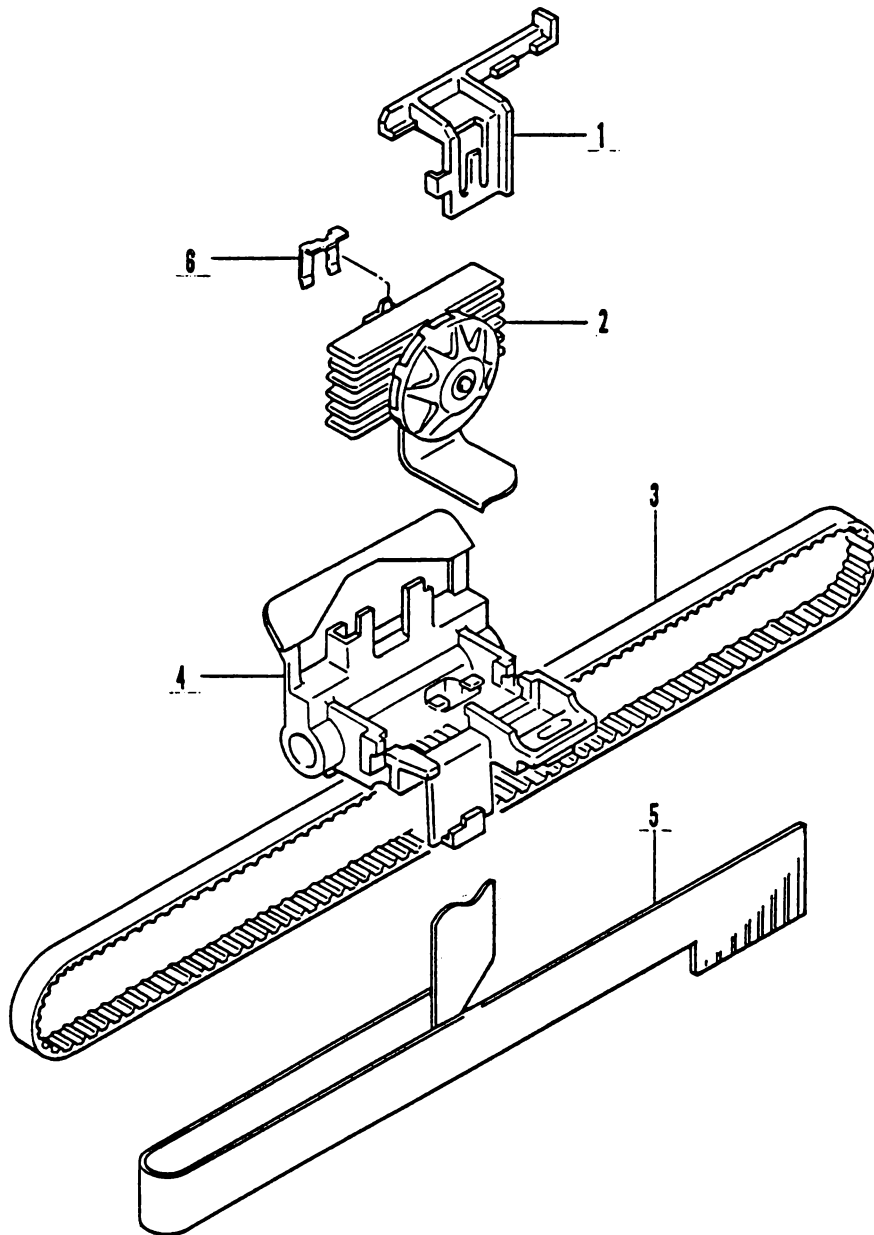

5.	Parts Code	Q'ty	Name
1	U23007000	1	HOLDER PLATE
2	U23300001	1	HEAD ASSY P8
3	U23017001	1	T BELT MM310-3.2
4	U23006000	1	CARRIAGE
5	U23159000	1	HEAD CABLE SHEAT A
6	U23008000	1	HEAD HOLDING SPRING

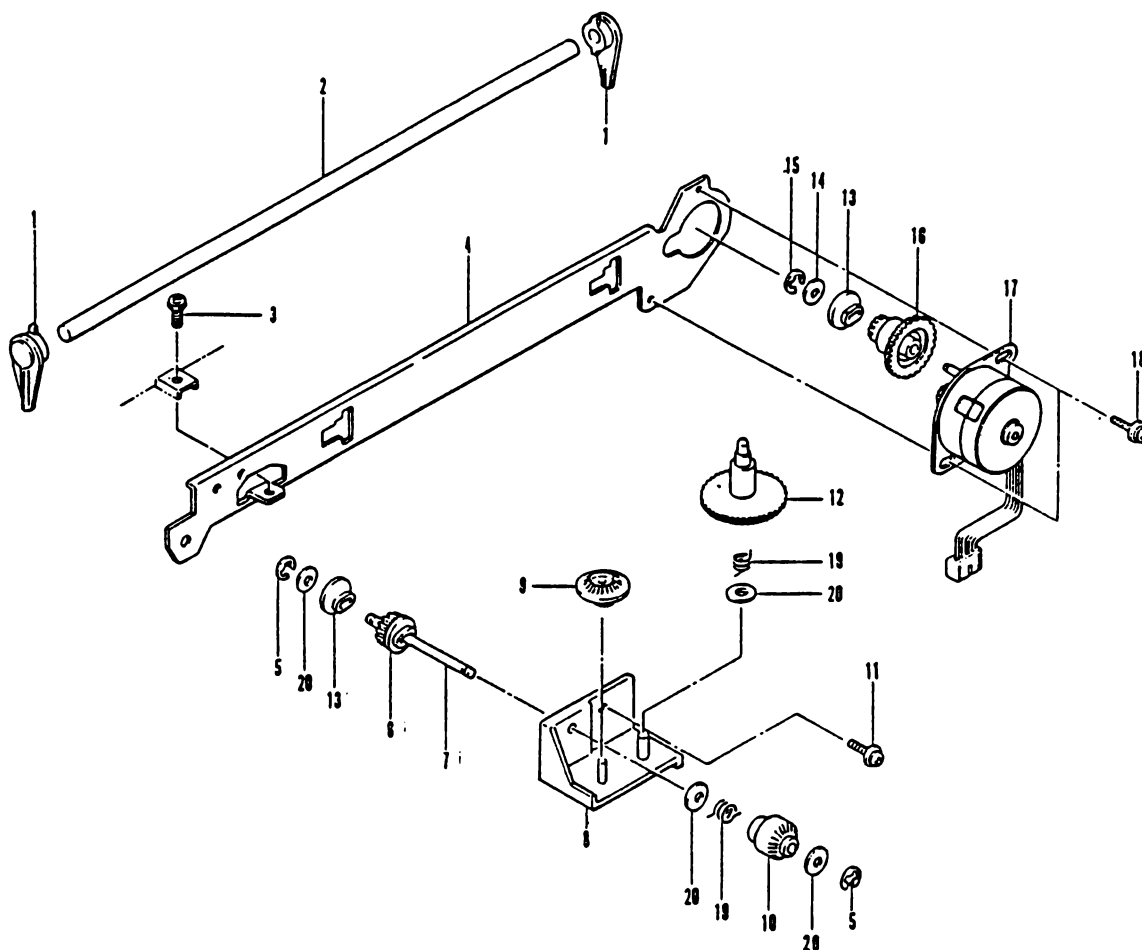

6.	Parts Code	Q'ty	Name
1	U23010000	2	PARALLELISM ADJUSTING CAM
2	U23009001	1	GUIDE BAR
3	533527001	1	+ PAN SEMS 3 x 8DB
4	U23016001	1	FRAME PLATE
5	048040345	2	E4 RETAINING RING
6	U23022001	1	CARRIAGE IDLE PULLEY
7	U23023001	1	CARRIAGE I PULLEY
8	U23019001	1	I PULLEY HOLDER ASSY
9	U23026000	1	RIBBON IDLE GEAR
10	U23024000	1	PF CLUTCH GEAR
11	533527001	1	+ PAN SEMS 3 x 8DB
12	U23027001	1	RIBBON DRIVING GEAR

13	U04130000	2	CARRIAGE I PULLEY FLANGE
14	025040133	1	FLAT WASHER SMALL 4
15	048030345	1	RETAINING RING E3
16	U23015000	1	C DRIVING PULLEY
17	Z20251001	1	42CR MOTOR ASSY
18	533527001	2	+ PAN SEMS 3 x 8DB
19	U23025001	2	SPRING CLUTCH 5
20	510061001	2	WASHER
21	025050135	1	FLAT WASHER SMALL 5

- NOTE(1) Parts code of ASSY of 13-17 above, U23014001 CR MOTOR
UNIT ASSY
- (2) Parts code of ASSY of 5-10 and 12-13 above, U23018001
I PULLEY UNIT ASSY

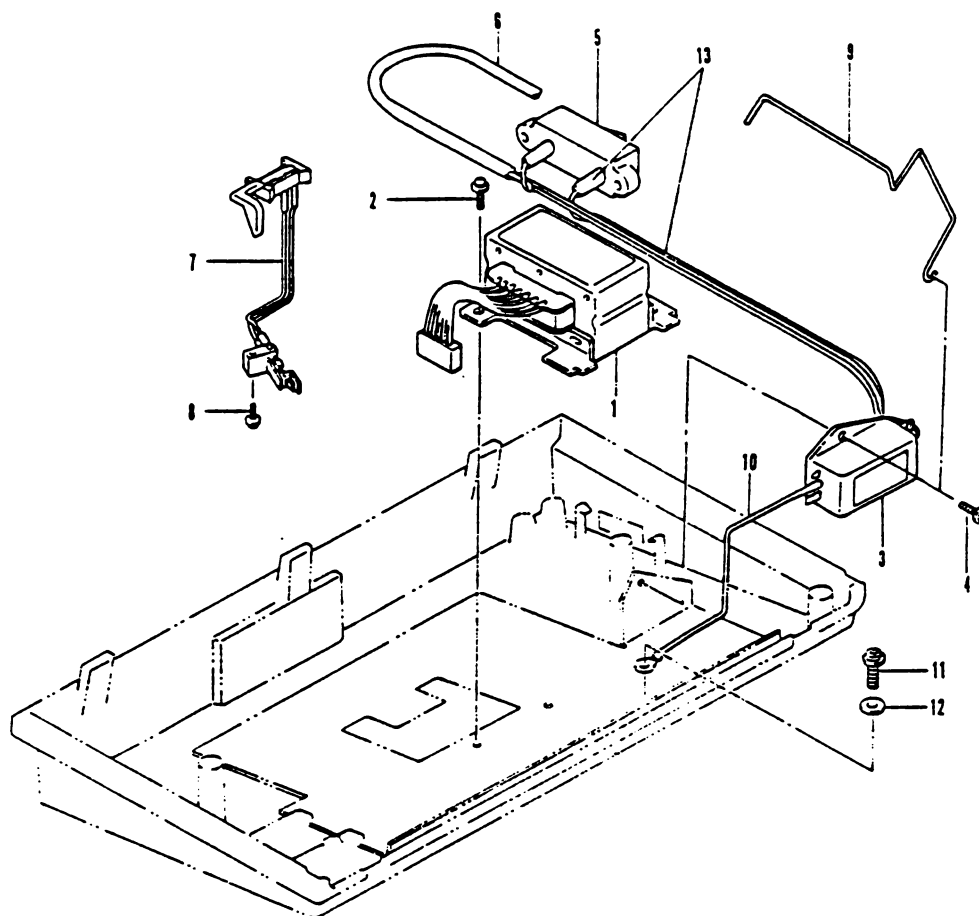

7.	Parts Code	Q'ty	Name
1	U32148001	1	TRANSFORMER 100/117 ASSY
	U32149001	1	TRANSFORMER 220/240 ASSY
2	519475002	2	COLLAR SCREW 3.5 x 6
3	U32150001	1	NOISE FILTER MR2021
	U32151001	1	NOISE FILTER MR2021V
4	U03292001	1	+ - PAN SEMS 3 x 7DA
5	U32159001	1	PROTECTOR SW0.5A
	U32160001	1	PROTECTOR SW0.4A
6	U32153001	1	565 AC CORD ASSY #1
	U32042001	1	565 AC CORD ASSY #2
	U32052001	1	565 AC CORD ASSY #3
	U32164001	1	565 AC CORD ASSY #4
	U32231001	1	565 AC CORD ASSY #5
	U32251001	1	565 AC CORD ASSY #6

7	U32242001	1	PE/HP HARNESS WHOLE-ASSY
8	037281213	1	PAN TAP 2 TYPES 26 x 12
9	U23175000	1	ELECTROSTATIC WIRE
10	U32161001	1	FG WIRE ASSY
11	519475002	1	COLLAR SCREW 3.5 x 6
12	550719002	1	RING 4
13	U32152001	1	SW-NF WIRE ASSY

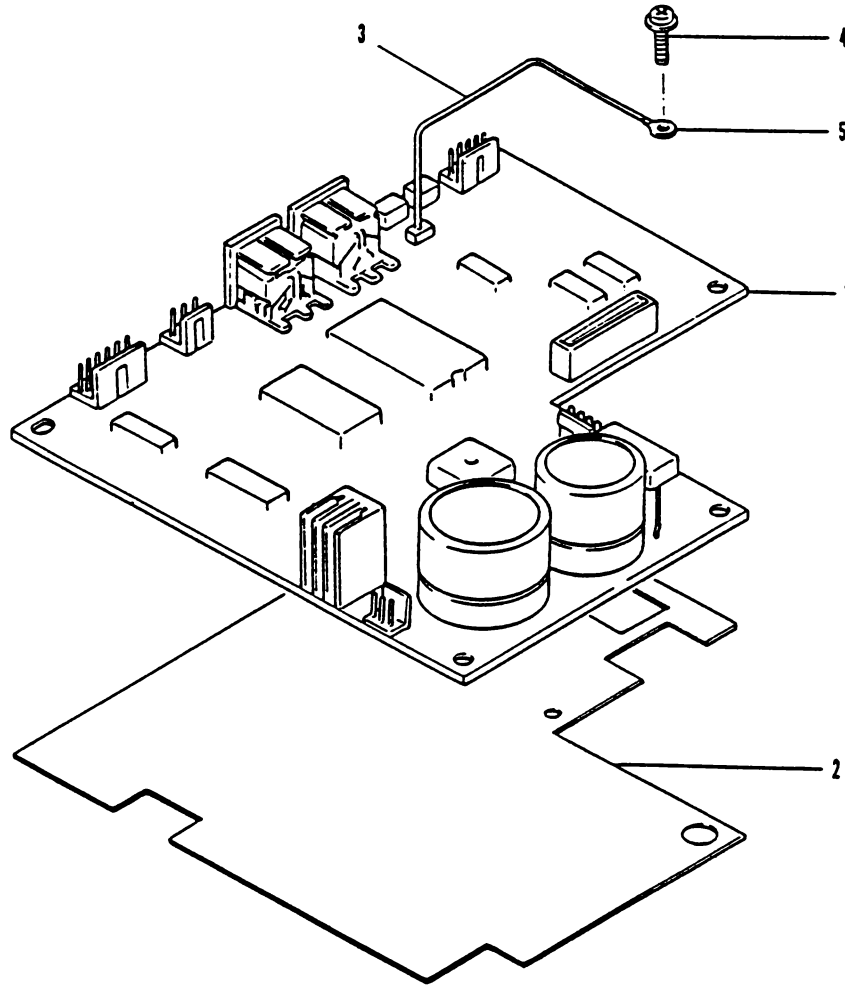

8.	Parts Code	Q'ty	Name
1	U32027001	1	CIRCUIT BOARD 8W005 ASSY #0
2	U23058000	1	INSULATOR
3	U32158001	1	INT FG WIRE ASSY
4	519475002	1	COLLAR SCREW 3.5 x 6
5	550719002	1	RING 4

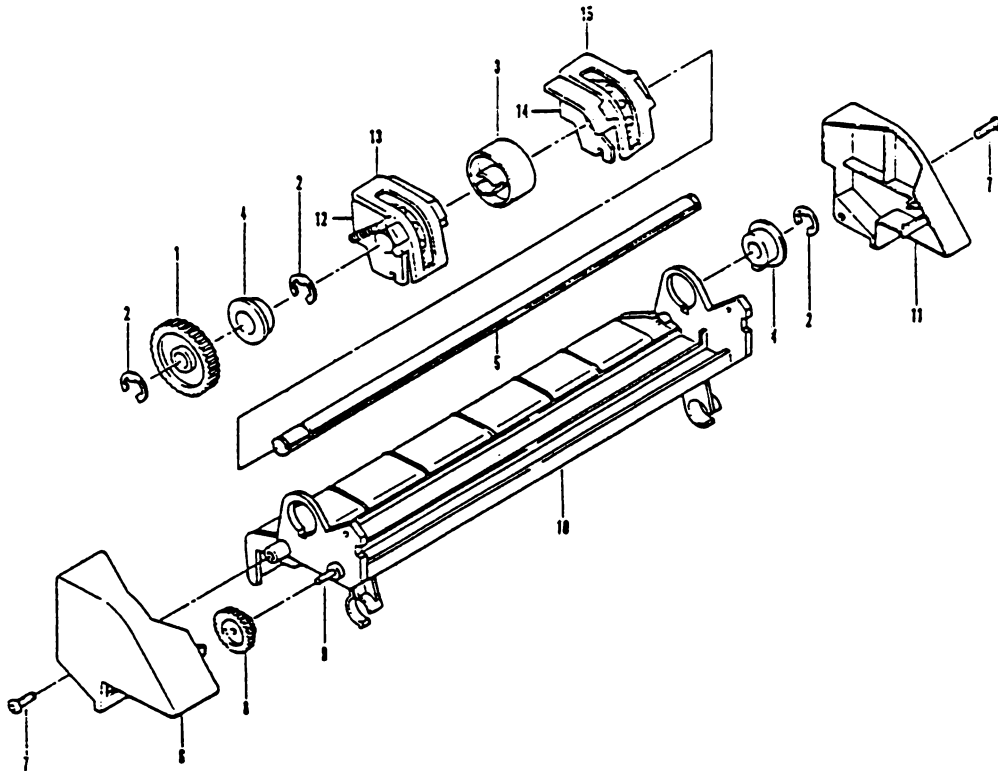

 9. Optional

	Parts Code	Q'ty	Name
1	U23066001	1	W DRIVING GEAR
2	048050346	3	RETAINING RING E5
3	U23076001	1	PAPER WHEEL
4	U23068001	2	BEARING
5	U23067001	1	W DRIVE SHAFT
6	U23081001	1	PIN FEED COVER L
7	037260812	2	PAN TAPPING V SHOE 2.6
8	U23064001	1	W IDLE GEAR
9	U23063001	1	W IDLE GEAR SHAFT
10	U23062001	1	PIN FEED FRAME
11	U23080001	1	PIN FEED COVER R
12	U23070001	1	WHEEL FRAME L
13	U23071001	1	WHEEL DOOR L
14	U23074001	1	WHEEL FRAME R
15	U23075001	1	WHEEL DOOR R
16	U23072001	1	PIN WHEEL

 NOTE: Parts code of ASSY of 1-16 above, U23061001 TRACTOR UNIT.

CHAPTER 7
TROUBLESHOOTING

TROUBLESHOOTING

Trouble mode	Check	Probable causes
(1) Does not operate by POWER ON. (POWER LED off)	<ul style="list-style-type: none"> ◦ Connectors for power supply ◦ Fuse ◦ Power supply voltage 	<ul style="list-style-type: none"> ◦ Incomplete connection from the power cord to transformer connector. ◦ Fuse failure or regulator 805 trouble on the logic card.
(2) Does not operate by POWER ON. (POWER LED on)	<ul style="list-style-type: none"> ◦ POWER LED is flickering. ◦ +24V power supply voltage is normal. 	<ul style="list-style-type: none"> ◦ When flickering, MOTOR ERROR is suspected. CARRIAGE DRIVER CIRCUIT or CR MOTOR trouble. ◦ MOTOR ERROR occurs when +24V is not supplied. Fuse or rectifier bridge on the logic card trouble. Power transformer trouble. ◦ When not flickering, ROM CHECK ERROR is suspected. CPU trouble or RESET signal circuit trouble.
(3) Head does not move to center at POWER ON.		<ul style="list-style-type: none"> ◦ Same as above. HP switch trouble.
(4) Incorrect printing	<ul style="list-style-type: none"> ◦ Interface cable is appropriate. 	<ul style="list-style-type: none"> ◦ May print incorrectly if the cable is too long. ◦ CPU on the logic card trouble.
(5) Carriage moves but does not print.	<ul style="list-style-type: none"> ◦ Head cable is correctly connected. 	<ul style="list-style-type: none"> ◦ Head cable is not inserted to the connector. ◦ Trouble around transistor Q10.
(6) Specific pins are not impacted.	<ul style="list-style-type: none"> ◦ Replace head. 	<ul style="list-style-type: none"> ◦ Head trouble. ◦ CPU and head driver IC trouble Correct head resistance approx. 33Ω Connector pins No.5 and No.6 are common.

<p>(7) LF Motor becomes disordered.</p>	<ul style="list-style-type: none"> ◦ Mechanically heavy-loaded. ◦ Gears cause racing. 	<ul style="list-style-type: none"> ◦ If mechanical factors are not suspected, the LF driver IC on the logic card and CPU trouble. LF motor resistance: approx. 160Ω GREEN COMMON
<p>(8) CR motor becomes disordered.</p>	<ul style="list-style-type: none"> ◦ Mechanically heavy-loaded such as ribbon load. ◦ Gears cause racing. 	<ul style="list-style-type: none"> ◦ If mechanical factors are not suspected, the carriage driver IC on the logic card and CPU trouble. Trouble around transistor 08. CR motor resistance: approx. 106Ω RED COMMON
<p>(9) At POWER ON, POWER LED does not come on though carriage correctly operates.</p>	<ul style="list-style-type: none"> ◦ Connector P5 is correctly connected. 	<ul style="list-style-type: none"> ◦ LED on switch panel trouble. ◦ Transistors Q1 & Q2 on logic card trouble.
<p>(10) DEVICE NOT PRESENT ERROR occurs.</p>	<ul style="list-style-type: none"> ◦ LISTENER ADDRESS setting. 	<ul style="list-style-type: none"> ◦ If setting is correct, SW1 trouble. CPU port trouble.
<p>(11) Amount of line feed is incorrect.</p>	<ul style="list-style-type: none"> ◦ Line feed setting. 	<ul style="list-style-type: none"> ◦ If setting is correct, SW2 trouble. CPU port trouble.



This was brought to you

from the archives of

<http://retro-commadore.eu>